

Section 4

Power Monitoring and Control

PowerLogic™ Energy and Power Management Systems 4-2

Power Monitoring Software	4-4
StruxureWare Power Monitoring Expert Software	4-4
StruxureWare PowerSCADA Expert	4-6
Power Quality Meters — ION8650	4-7
ION8650 Power and Energy Meters	4-7
ION7550 and ION7650 Power and Energy Meters	4-8
Series 4000 Circuit Monitor	4-9
PowerLogic ION7400 Utility Feeder Meter	4-10
PowerLogic PM8000 Power and Energy Meters	4-11
Power Quality Meter Selection	4-12
Power and Energy Meters — PM5000 Series	4-13
Series 5000 Power Meters	4-13
ION6200 Power and Energy Meter	4-13
Series 3500 Energy and Power Meter	4-14
PowerLogic PM3000 Power and Energy Meters	4-15
iEM3000 Energy Meters	4-16
Power and Energy Meter Selection	4-18
PowerLogic Energy Meter	4-19
PowerLogic EM4200 Enercept Meter	4-19
PowerLogic Enercept™ Meter	4-20
Multi Circuit Energy Meters	4-21
PowerLogic Branch Circuit Power Meter	4-22
PowerLogic Multi-Circuit Meter	4-24
PowerLogic Submeter Display	4-24
Communications	4-25
Com'X Data Loggers and Energy Servers	4-25
Link150 Ethernet Gateway	4-26
Engineering Services	4-27
Integration and Equipment	4-29
System Integration	4-29
Factory Assembled Equipment	4-29
PowerLogic High Density Metering	4-31
Support Services	4-32

Septom Digital Protective Relays 4-33

Arc Flash Protection and Mitigation Systems 4-35

Reactive™ 4-36

Reactive Power Compensation and Harmonic Mitigation	4-36
Low Voltage Fixed Capacitors	4-37
LV Standard Automatic Capacitor Banks	4-38
LV Anti-Resonant and Filtering Automatic Capacitor Banks	4-38
Current Transformer Selection Information	4-39
LV Transient Free Reactive Compensation Capacitor Banks	4-39
Medium Voltage Fixed Capacitors	4-40
Medium Voltage Metal Enclosed Capacitor Systems	4-41
High Voltage Reactive Power Compensation Systems	4-41

AccuSine™ 4-42

PCS+ Active Harmonic Filter	4-42
PFV+ Active Harmonic Filter	4-43
Current Transformers	4-44
Hybrid VAR Compensator (HVC)	4-45

VarSet Low-Voltage Capacitor Banks 4-46



StruxureWare Power Monitoring Expert Software



ION8650 Power and Energy Meters



ION7550 and ION7650 Power and Energy Meters



PowerLogic PM8000 Power and Energy Meters



CM400T with VFD Display

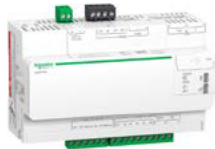

Com'X Data Loggers and Energy Servers



Ethernet Gateways



Sepam Series 80



Vamp 321 Arc Flash Protection and Mitigation



ReactiVar Low Voltage Automatic Capacitor Bank



AccuSine PCS+



AccuSine PFV+



VarSet Low-Voltage Capacitor Banks

POWER MONITORING AND CONTROL

Join the Next Generation of Power and Energy Management
More performance. More intelligence. More integration.

Our industry-leading systems offer the latest in technological advancements to help you simultaneously maximize reliability, availability, and quality, as well as improve operational and cost efficiency for your entire enterprise. You'll benefit from:

- **Holistic approach**
Our solutions aggregate data from all your energy assets, including power, building, and process systems, into one user-friendly view so you can make more informed decisions and address problems efficiently.
- **Actionable intelligence**
Our solutions provide real-time and historical information to multiple stakeholders anywhere in the world, including easy-to-use analytics, alarms and controls, as well as regulatory compliance and financial reporting.
- **Proactive capabilities**
Our sophisticated products help you analyze and identify future needs so you can develop a long-term plan for things like energy purchasing, demand response, load changes, and equipment maintenance or replacement.



Advanced Power Management

Delivers power quality, availability, and reliability



Superior Energy Management

Delivers cost and operational efficiencies

Don't settle for fragmented views and unreliable data

Maximize performance with a fully integrated power management solution

You'll benefit from our decades of expertise in electrical system management, hardware and software development, and integration. Our solutions are designed for compatibility so your installation is both optimized and more efficient. Our systems are modular and interoperable for better continuity of supply, enhanced safety for people and equipment, and more effective monitoring and control. Plus, our full range of in-person and remote services keep your system operating at peak performance.



Application

		Data Presentation & Management		Data Acquisition, Alarms & Monitoring		
		Enterprise	Online Energy Analysis	Supervisory Control & Data Acquisition	Power Monitoring System	Tenant Submetering
		Data Centers Industrial Buildings, Property Management, Utilities	Utilities	Water/Wastewater, Heavy Process Industry, Data Centers, Critical Power	Industrial, large commercial buildings, Military Bases, Healthcare	Commercial Buildings, Government Buildings, Military Bases
Cost Management	Meter Application					
	Automatic Meter Reading		
	Revenue Metering		
	WAGES Utility Pulses				...	
	Sub-billing
	Measurement & Verification	
	Cost Allocation & Utility Billing					
	Energy Usage Analysis
	Procurement Optimization	
	Allocate Energy Costs	.			.	
	Interval Benchmarking & Profiling	
	Total Load Aggregation				
	Energy Efficiency					
	Emissions Tracking			
	Power Factor Correction	
Peak Demand Reduction		
Demand Response & Curtailment				
Ensure Power Quality	Improve Maintenance Practices					
	Commissioning & Troubleshooting			
	Equipment Monitoring: transformers, MCCs, switchgear, switchboards, circuit breaker status, protective equipment, capacitors, generators, panelboards, PDU, UPS, etc.			
	Facility Planning					
	Identify Equipment Capacity				...	
	Determine Transformer Stress				...	
	Equipment Asset Optimization	
	Improve Efficiency					
	Balance Circuit Loading				...	
	Balance Generator Usage				...	
Network Management	System Monitoring & Analysis					
	Transient Voltage Detection				
	Sag/Swell Disturbance Monitoring				
	Power Quality & Harmonic Analysis				
	Power Quality Compliance	
	Alarm & System Diagnostics					
	Electrical Distribution Alarm & Event Analysis	
Waveform capture viewing					
Remote alarm notification				
Engineering Services	Energy Services					
	Total Energy Control Services	see Engineering Services, page 4-27		...	
	Peak Shaving/Generator Control			see Engineering Services, page 4-27
	Load Management/Shedding	see Engineering Services, page 4-27		
	WAGES				...	
	Advanced Reliability Services					
	Auto Throw Over (ATO)			
	Emergency Power Supply System Test Reporting				
	Sequence of Events Recording (1ms time/stamp)	see Engineering Services, page 4-27		see Engineering Services, page 4-27
	GPS Time Stamping			
	Power System Control			
	Network Protection			
Consulting Services						
System Studies (SC/TCC/ Arc Flash)			see Engineering Services, page 4-27			
Power System Assessments						



- Manage power quality, availability, and reliability
- Optimize use of your electrical and infrastructure assets
- Drive energy efficiency initiatives and improve financial performance

StruxureWare Power Monitoring Expert Software

StruxureWare Power Monitoring Expert

StruxureWare™ Power Monitoring Expert is an integrated power & energy management software platform that enables you to optimize your power distribution infrastructure, maximize operational efficiency, and improve your bottom-line performance. This complete, interoperable, and scalable solution will help you

- Maximize facility uptime and reliability
- Analyze and mitigate power quality related issues
- Track and optimize equipment performance
- Analyze energy consumption, uncover savings opportunities and accurately allocate energy related costs
- Enable compliance with power quality and energy standards such as ANSI/IEEE and ISO50001

Typical Applications

- Monitor the facility electrical network to verify reliable operation and proactively optimize performance
- Maximize facility uptime by improving response to power-related events and restore operations quickly
- Perform root cause analysis to power-related disturbances through sequence of events reporting
- Analyze and isolate the source of power quality problems
- Analyze total energy use from all electrical and piped utilities identify waste and reduce cost
- Improve sustainability performance with greenhouse gas emissions tracking and industry compliance reporting
- Identify billing discrepancies and avoid contract penalties by validating utility bills to verify accuracy
- Allocate energy costs to departments to drive accountability, awareness and support energy action programs like ISO50001
- Reduce peak demand and power factor penalties with monitoring, alerts, and corrective actions
- Negotiate rates with energy suppliers and enable participation in demand response programs
- Confirm return on investment for infrastructure improvements with advanced reporting and analysis
- Optimize existing infrastructure capacity and avoid over-building
- Prolong asset life with proactive maintenance and optimization

Functional Components:

- Power quality analytics
 - Monitor events and waveform plotting system-wide
 - Monitor harmonics, K-factor, crest factor, symmetrical components
 - Diagnose and isolate PQ problems to increase reliability
 - Automatically detect and report on voltage disturbances
 - Quickly evaluate PQ events plotted on standard ITIC curve
- Customized real-time monitoring
 - Access real-time status of sensitive power distribution components
 - Trend chart tools with customized views to reveal patterns and anomalies quickly
- Data analytics and visualization
 - Smart dashboards with configurable presentation widgets and kiosk options
 - Powerful graphics templates and libraries
 - Automated power quality reports and waveform analysis tools
 - Comprehensive templates for energy and power reporting, with flexible report distribution options
- Alarm and event management
 - Powerful alarm triggering, notification, and analysis tools
 - Accurate time-stamped sequence of events reporting for power system event root cause analyses
- Robust technical infrastructure
 - Solid data acquisition architecture including ready-to-use communications drivers with many electrical distribution devices
 - Fully compatible with current operating systems and databases
 - Interoperable with integration to other systems and devices through open data and protocol standards (ODBC, OPC, XML, Modbus, Web/SOAP Services)
 - Scalable to thousands of metered points through flexible deployment options



Modular Design:

Power Monitoring Expert also features many application modules that add specific functionality to extend the base platform. Available modules include

- Energy Analysis
- UPS Performance
- Breaker Performance
- Energy Cost Allocation & Billing
- Automated Generator Testing

Segment Editions:

Power Monitoring Expert also features segment-specific solutions for data centers, healthcare, industry and buildings, delivering pre-engineered functionality customized to meet your needs.



StruxureWare Power Monitoring Expert Data Center Edition

- Decrease the number and duration of unplanned outages
- Manage power capacity and redundancy
- Improve effectiveness of maintenance activities
- Improve power distribution efficiency
- Support energy cost allocation and billing



StruxureWare Power Monitoring Expert Data Healthcare Edition

- Improve energy availability
- Manage power system reliability
- Perform power quality analysis and management
- Support energy efficiency initiatives to improve financial performance



StruxureWare Power Monitoring Expert Data Buildings Edition

- Ensure electrical system health
- Optimize operational efficiency
- Gain energy insight
- Improve energy accountability

Description	Catalog Number
Power Monitoring Expert Standard Edition BASE license (includes 1 Engineering Client)	PSWSANCZSPEZZ
Power Monitoring Expert Data Center Edition BASE license (includes 1 Engineering Client)	PSWSDNCZSPEZZ
Power Monitoring Expert Healthcare Edition BASE license (includes 1 Engineering Client)	PSWSHNCZSPEZZ
Power Monitoring Expert Buildings Edition BASE license (includes 1 Engineering Client)	PSWSBNCZSPEZZ
5 Device Pack for Power Monitoring Expert software	PSWDANCZNPEZZ
25 Device Pack for Power Monitoring Expert software	PSWDBNCZNPEZZ
50 Device Pack for Power Monitoring Expert software	PSWDCNCZNPEZZ
100 Device Pack for Power Monitoring Expert software	PSWDDNCZNPEZZ
200 Device Pack for Power Monitoring Expert software	PSWDFNCZNPEZZ
Unlimited Devices for Power Monitoring Expert software	PSWDZNCZSPEZZ
Engineering Client for Power Monitoring Expert software	PSWCENCZNPEZZ
Web Client for Power Monitoring Expert software	PSWCWNCZNPEZZ
Unlimited Engineering and Web Clients for Power Monitoring Expert software	PSWCZNCZSPEZZ
Event Notification Module for Power Monitoring Expert software	PSWVMNCZSPEZZ
Cost Allocation & Billing Module for Power Monitoring Expert software	PSWMBNCZSPEZZ
Breaker Performance Module for Power Monitoring Expert software	PSWVMXNCZSPEZZ
Energy Analysis Module for Power Monitoring Expert software	PSWVMZNCZSPEZZ
Energy Awareness Module for Power Monitoring Expert software	PSWVMYNCZSPEZZ
UPS Performance Module for Power Monitoring Expert software	PSWVMUNCZSPEZZ
EPSS Module for Power Monitoring Expert software (HealthCare)	PSWVMENCZSPEZZ
Generator Performance Module for Power Monitoring Expert software (Data Centers)	PSWVMGNCZSPEZZ
IT Billing Module for Power Monitoring Expert software (Data Centers)	PSWVMTNCZSPEZZ
Power Capacity Module for Power Monitoring Expert software (Data Centers)	PSWVMPCZSPEZZ
Power Efficiency Module for Power Monitoring Expert software (Data Centers)	PSWVMNNCZSPEZZ
SQL Server 2012 License - 2 COREs	IETSQLCZSNPEZZ



StruxureWare PowerSCADA Expert

- Increase uptime of power systems
- Provides accurate and actionable information in real time
- Highlights issues, remediation, and their impacts

StruxureWare™ PowerSCADA Expert is electrical distribution network monitoring and control software that provides vital tools to enhance your power system reliability and operational efficiency. Its powerful architecture combines our proven expertise in electrical distribution with the speed and control of high-performance SCADA to reduce outages while increasing power system efficiency. An excellent fit for virtually every industry and application, PowerSCADA Expert delivers exceptional scalability so that it can grow to match your changing business requirements while driving down the total cost of ownership. Components interact seamlessly across Schneider Electric's extensive product portfolio and third party suppliers.

- Dynamic electrical network view to improve production, reduce costs and boost safety
- Highly reliable monitoring and control tailored to unique electrical network needs
- Detailed electrical information across the multi-vendor network
- Fast issue resolution and reporting to improve electrical network quality and energy use
- Report KPIs, energy costs, and filtered alarming
- Real-time visualization of the network
- Disturbance waveform views for analysis and control for remediation

For quoting and pricing, please contact PowerLogic Sales at

PowerLogic ION EEM Software

PowerLogic™ ION EEM is a complete Enterprise Energy and Sustainability Management System (EESMS) to provide energy data warehousing capabilities, integrating data from multiple sites and disparate systems. For example, the EESMS will be capable of integrating data from building and process systems, power management systems, energy billing and pricing systems, business and accounting systems, weather services, spot-market energy pricing feeds etc. to facilitate green economic policies (such as reducing CO2 emissions), energy conservation measures, or sustainability targets.

Typical applications:

- Display visually rich energy intelligence dashboards to drive energy behavior change.
- Allocate costs and usage across facilities, departments, and other organizational units.
- Benchmark, measure and verify energy key performance indicators for performance versus target.
- Track and manage environmental impact carbon/GHG emissions and carbon inventories (by source, scope and pollutant), using appropriate global emission factors.
- Reduce peak demand surcharges and power factor penalties.
- Identify billing discrepancies.
- Model energy accurately using statistical regression techniques.
- Forecast energy needs and compare rates for efficient procurement.
- Facilitate participation in load curtailment programs.
- Track performance of energy and sustainability programs, and assess cumulative savings and return on investments.
- Manage energy and sustainability projects and scenarios and assess potential financial impact prior to implementation.
- Store and manage energy invoices in a central repository.

Key features:

- True enterprise-level software architecture: data quality assurance, data warehouse, web framework
- Web portal: personalized dashboards, key performance indicators, charts, trends, real-time conditions
- Reporting: rich and customized content, support for complex data and graphics, scheduled distribution
- Trending: advanced visualization, dimensional analysis, prediction, statistical rollups
- Modeling: regression analysis, normalization, correlation, integration of all relevant drivers and contextual data
- Billing: built-in rate engine and rate wizard
- Power quality analysis: wide-area event monitoring, classification, filtering, correlation
- Alarms and events: triggering on complex conditions, notification, logging
- Integration: data acquisition systems, weather and pricing feeds, other enterprise applications (e.g. BAC, ERP)
- Greenhouse Gas Emissions (CO2) Reporting

For quoting and pricing, please contact PowerLogic Sales at



Personalized dashboards help management and operations personnel monitor all aspects of energy use

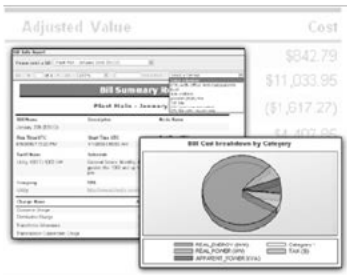

Produce aggregate billing, load profile, cost allocation, power quality, forecasting or budget reports to help inform stakeholders and track results against goals.



ION8650 Power and Energy Meters

The web-enabled PowerLogic ION8650 is used to monitor electric distribution networks, service entrances and substations. It enables businesses to manage complex energy supply contracts that include power quality guarantees. Low-range current accuracy makes it ideal for independent power producers and cogeneration applications that require the accurate bi-directional measurement of energy. It is well suited to load curtailment, equipment monitoring and control and energy pulsing and totalization applications. Integrate it with Power Management Software applications.

ION8650 Power and Energy Meter Features

Feature set C includes:

- 9S, 35S, 36S socket and switchboard cases
- True RMS 3-phase voltage, current, power and meets stringent ANSI revenue metering standards including ANSI C12.20 0.2 and Class 2, 10, & 20
- Power quality: sag/swell, individual, even, odd, total harmonics to the 31st and symmetrical components
- 32MB log/event memory, min/max for any parameter, historical logs up to 80 channels, timestamp resolution to 0.001 seconds and GPS time synchronization
- Transformer/line loss compensation and Instrument transformer correction
- Communications: Ethernet, Serial, Modem, Internet and Ethernet to serial gateway and ION, DNP 3.0, Modbus RTU, Modbus TCP, MV-90 protocols, IEC 61850
- C model limited to IR + 2 other ports at one time. Ports can be enabled/disabled by user
- Dial-out capability when memory is near full
- Multi-user, multi-level security with control and customized access to sensitive data for up to 50 users
- Data push capability through SMTP (email)
- 65 setpoints — math, logic, trig, log, linearization formulas
- Password protection and anti-tamper seal protection
- Built-in I/O: 4 KYZ digital outs and 3 form A digital ins, 4 KYZ digital outs and 1 form A digital out and 1 form A digital in, an optional external I/O expander provides additional I/O

Feature set B adds the following to feature set C:

- Harmonics—individual, total even, total odd up to the 63rd
- 64MB standard memory
- Historical logs up to 320 channels
- Modbus RTU Master on serial ports
- Cycle setpoint minimum response time

Feature set A adds the following to feature sets C and B:

- Waveform capture up to 1024 samples/cycle, PQ compliance monitoring, flicker to EN50160 Ed2, IEC 61000-4-7/4-15 (also configurable to IEC61000-4-11, IEC61000-4-12, IEC61000-4-13, IEC61000-4-14, IEC61000-4-15, IEC61000-4-16, IEC61000-4-17, IEC61000-4-18, IEC61000-4-19, IEC61000-4-20, IEC61000-4-21, IEC61000-4-22, IEC61000-4-23, IEC61000-4-24, IEC61000-4-25, IEC61000-4-26, IEC61000-4-27, IEC61000-4-28, IEC61000-4-29, IEC61000-4-30, IEC61000-4-31, IEC61000-4-32, IEC61000-4-33, IEC61000-4-34, IEC61000-4-35, IEC61000-4-36, IEC61000-4-37, IEC61000-4-38, IEC61000-4-39, IEC61000-4-40, IEC61000-4-41, IEC61000-4-42, IEC61000-4-43, IEC61000-4-44, IEC61000-4-45, IEC61000-4-46, IEC61000-4-47, IEC61000-4-48, IEC61000-4-49, IEC61000-4-50, IEC61000-4-51, IEC61000-4-52, IEC61000-4-53, IEC61000-4-54, IEC61000-4-55, IEC61000-4-56, IEC61000-4-57, IEC61000-4-58, IEC61000-4-59, IEC61000-4-60, IEC61000-4-61, IEC61000-4-62, IEC61000-4-63, IEC61000-4-64, IEC61000-4-65, IEC61000-4-66, IEC61000-4-67, IEC61000-4-68, IEC61000-4-69, IEC61000-4-70, IEC61000-4-71, IEC61000-4-72, IEC61000-4-73, IEC61000-4-74, IEC61000-4-75, IEC61000-4-76, IEC61000-4-77, IEC61000-4-78, IEC61000-4-79, IEC61000-4-80, IEC61000-4-81, IEC61000-4-82, IEC61000-4-83, IEC61000-4-84, IEC61000-4-85, IEC61000-4-86, IEC61000-4-87, IEC61000-4-88, IEC61000-4-89, IEC61000-4-90, IEC61000-4-91, IEC61000-4-92, IEC61000-4-93, IEC61000-4-94, IEC61000-4-95, IEC61000-4-96, IEC61000-4-97, IEC61000-4-98, IEC61000-4-99, IEC61000-4-100)
- Transient detection to 6517µs at 60Hz;
- Harmonics: magnitude, phase and inter-harmonics to the 50th
- 128MB standard memory
- Max 96 cycles of waveform logs and 800 channels of historical logs

Table 4.1: Typical PowerLogic ION8650 Power and Energy Meter Ordering Configurations

Description	Catalog No.
ION8650, feature set A, 9S socket base, 5 A nominal current inputs, 10MB memory, 127–177 Vac, 60 Hz, communications card with: 10BaseT, RS-232/485, RS-485, Optical port, 4 Digital Outputs, 3 Digital Inputs	S8650A0C0E6E1B0A
ION8650, feature set A, 35S socket base, 5 A nominal current inputs, 10MB memory, 120–480 Vac, 60 Hz, communications card with: 10Base T, RS-232/485, RS-485, Optical port, 4 Digital Outputs, 3 Digital Inputs	S8650A1C0E6E1B0A
ION8650, feature set C, 9S socket base, 5 A nominal current inputs, 2MB memory, 120–277 Vac, 60 Hz, communications card with: RS-232/485, RS-485, Optical port, 4 Digital Outputs, 3 Digital Inputs	S8650C0C0E6A0B0A
ION8650, feature set C, 35S socket base, 5 A nominal current inputs, 2MB memory, 120–277 Vac, 60 Hz, communications card with: RS-232/485, RS-485, Optical port, 4 Digital Outputs, 3 Digital Inputs	S8650C1C0E6A0B0A



ION7550 and ION7650 Power and Energy Meters

Used at key distribution points and sensitive loads, the web-enabled PowerLogic ION7550 and PowerLogic ION7650 meters combine a wealth of advanced features from power quality analysis capabilities, revenue accuracy and multiple communications options, through web compatibility, and control capabilities. Both are compatible with PowerLogic Power Management Software applications and can be integrated with other energy management or building control systems through multiple communication channels and protocols.

The meters are ideal for compliance monitoring, disturbance analysis, cost allocation and billing, demand and power factor control and equipment monitoring and control. The meters have a high visibility, adjustable front panel display that can depict TOU, harmonics, event logs, phasers, and instantaneous power parameters. They meet stringent ANSI C12.20 0.2, Class 10 & 20 revenue metering standards.

PowerLogic ION7550 and ION7650 Power and Energy Meter Features:

- 3.5" x 4.5" (87 x 112 mm) backlit LCD display
- True RMS 3-phase voltage, current, and power that meets stringent ANSI C12.20 0.2, Class 2, 10, & 20
- Power quality: sag/swell, harmonics - individual, even, odd, total to the 63rd, waveform capture at 256 samples/cycle
- 5MB log/event memory (10MB optional), waveform logging up to 96 cycles, up to 800 channels historical, min/max, timestamp resolution to 0.001 seconds, GPS time synchronization and historical trends through front panel
- Communications: fiber, Ethernet, serial, internal modem, optical port, and a gateway functionality, ION, DNP 3.0, Modbus RTU - master & slave, Modbus TCP, MV-90, and IEC 61850. IEC 61850 only available with Ethernet options
- Dial-out capability when memory is near full
- Data push capability through SMTP (email)
- Multi-user, multi-level security with control and customized access to sensitive data for up to 16 users
- 65 configurable 1/2 cycle setpoints for single, multi-condition and dial out on alarm and math, logic, trig, log, linearization formulas
- Password protection and anti-tamper seal protection enhance meter security
- Extensive standard I/O includes: 8 digital inputs, 4 digital outputs and 3 onboard relays
- Disturbance direction detection determines disturbance location and direction relative to the meter.
- Alarm setpoint learning analyzes the circuit and recommends optimum alarm setpoints to minimize nuisance or missed alarms.
- Customize metering or analysis functions at your work station, without hard wiring via ION Frameworks technology.

The ION7650 has all the features of the ION7550 and adds:

- Waveform capture up to 1024 samples/cycle
- Transient detection to 17µs at 60Hz
- Harmonics: magnitude, phase and inter-harmonics to the 40th
- Flicker to EN50160 and IEC 61000-4-7/4-15 (also configurable for IEEE 519-1992, IEEE159, SEMI), plus CBEMA/ITIC
- Symmetrical components
- Power quality measurements per IEC 61000-4-30 Class A, Ed. 2

Table 4.2: Typical PowerLogic ION7550/7650 Power and Energy Meter Ordering Configurations

Description	Catalog No.
Typical PowerLogic ION7550 Power and Energy Meter Ordering Configurations	
Integrated display, with 256 samples/cycle, 5 MB logging memory, 5 A inputs, standard power supply, standard comms. (1 RS232/RS485 port, 1 RS485, 1 Type 2 optical port) plus Ethernet, standard I/O	S7550A0C0B6E0A0A
Integrated display, with 256 samples/cycle, 5 MB logging memory, 5 A inputs, standard power supply, standard comms. (1 RS232/RS485 port, 1 RS485, 1 Type 2 optical port), standard I/O	S7550A0C0B6A0A0A
Typical PowerLogic ION7650 Power and Energy Meter Ordering Configurations	
Integrated display, with 1024 samples/cycle, 10 MB logging memory, 5 A inputs, standard power supply, standard comms. (1 RS232/RS485 port, 1 RS485, 1 Type 2 optical port) plus Ethernet, standard I/O, EN50160 compliance monitoring	S7650B1C0B6E0A0E
Integrated display, with 512 samples/cycle, 5 MB logging memory, 5 A inputs, standard power supply, standard comms. (1 RS232/RS485 port, 1 RS485, 1 Type 2 optical port) plus Ethernet, standard I/O	S7650A0C0B6E0A0A
Integrated display, with 512 samples/cycle, 5 MB logging memory, 5 A inputs, standard power supply, standard comms. (1 RS232/RS485 port, 1 RS485, 1 Type 2 optical port) plus Ethernet and 56k modem, standard I/O	S7650A0C0B6C1A0A
Integrated display, with 512 samples/cycle, 5 MB logging memory, 5 A inputs, standard power supply, standard comms. (1 RS232/RS485 port, 1 RS485, 1 Type 2 optical port), standard I/O	S7650A0C0B6A0A0A
Integrated display, with 1024 samples/cycle, 10 MB logging memory, 5 A inputs, standard power supply, standard comms. (1 RS232/RS485 port, 1 RS485, 1 Type 2 optical port) plus Ethernet, standard I/O	S7650B1C0B6E0A0A

NOTE: Please refer to www.schneider-electric.us for the most complete and up-to-date list of feature availability. Some features are optional.



CM4000T with VFD Display

Series 4000 Circuit Monitor

The award winning, Web-enabled PowerLogic Series 4000 Circuit Monitor (CM4000T) is the most advanced permanently mounted circuit monitor in the industry today. Designed for critical power and large energy users who cannot afford to be shut down, the CM4000T provides the ability to monitor, troubleshoot and preempt power quality problems. Transients (disturbances lasting less than one cycle) are particularly difficult to detect, due to their short duration. The CM4000T detects and captures oscillatory and impulsive transients (up to 10,000V peak, line-to-line at 5 MHz per channel) as short as one microsecond in duration. The CM4000T automatically performs a high-speed transient waveform capture and a longer disturbance capture to show the conditions surrounding an event. The CM4000T maintains a complete historical record of the number of transients per phase, along with the magnitude, duration and time of occurrence of each. It also performs a stress calculation to determine the circuits that have received the greatest stress from transient overvoltages.

- Waveform capture with up to 512 samples/cycle
- Built-in Trending and Forecasting functionality allows you to forecast energy usage up to 4 days in advance
- Sag/Swell disturbance monitoring
- Two option card slots for field installable cards
- Optional field installable Ethernet communications card with standard and custom web pages
- Alarm Setpoint Learning feature allowing optimum threshold setting (patent pending)
- Multiple alarms: standard, digital, Boolean, high-speed, and disturbance alarms
- Waveshape alarm monitoring
- High speed transient voltage detection at 5 MHz per channel with field installable CVMT current/voltage module
- True RMS Metering through the 255th harmonic
- Extended waveform capture (up to 110 seconds)
- Field installable Digital/Analog I/O cards and flexible I/O extender modules
- Harmonic powerflows up to the 40th harmonic
- Standard KYZ pulse output
- Standard 32 MB of non-volatile memory
- Integrated power quality standards including EN50160, IEC 61000-4-15 (Flicker)
- Sequence of events recording using GPS synchronization technology
- Oscillatory transient detection and recording
- UL Listed, CSA Approved, NOM Approved, FCC compliant

PowerLogic Series 4000 Circuit Monitor Optional Displays

- High visibility remote VF (vacuum fluorescence) display
- Displays metering data, min/max values, alarms, inputs
- Remote LC (liquid crystal) display with backlighting also available
- Optional user configurable display screens

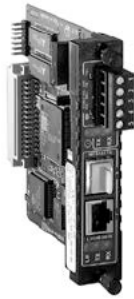

ECC21



IOC44 I/O Card

Table 4.3: Series 4000 Circuit Monitors

Description	Catalog No.
Series 4000 Circuit Monitors	
Instrumentation, On-board Data Logging, Waveform Capture, Disturbance Recording, Configurable I/O, 0.04% Accuracy, Impulsive Transient Detection and Flicker (IEC 61000-4-15)	CM4000T
Series 4000 Circuit Monitor Accessories	
Field installable I/O card with 3 relay outputs, 1 pulse output (KYZ) and 4 status inputs	IOC44
I/O Extender module with 4 DC status inputs, 2 DC digital outputs, 1 analog input and 1 analog output	IOX2411
I/O Extender module with 4 status inputs and 4 analog inputs (4–20 mA)	IOX0404
I/O Extender module with 8 status inputs	IOX08
I/O Extender module with no pre-installed I/O [1]	IOX
Ethernet Communications Card; 100 MB Fiber or 10/100 MB UTP Ethernet port and 1 RS-485 master port	ECC21
Current/Voltage module with high speed transient detection	CVMT
4-line x 20—character liquid crystal display with backlighting	CMDLC
4-line x 20—character vacuum fluorescent display with proximity sensor	CMDVF
4 foot display cable	CAB4
12 foot display cable	CAB12
30 foot display cable	CAB30

Table 4.4: SER Time Synchronization

Description	Catalog No.
PowerLogic Satellite Time System, Circuit Monitor and SEPAM GPS Time Synchronization, 100 microsecond accuracy	STS3000
Satellite Time Reference Module	STRM
CyTime Sequence of Events Recorder, 24 Vdc power / 24 Vdc inputs, 32 inputs, web server	9788SER3200
SER 3200 EZ connector for IRIG-B signal	9788EZC RIGB
Smart Antenna Module	SAM
Smart Antenna Module Interface Cable—200 FT	SA F200
Power Supply, 24DC/50W, D N-mountable	PS080

[1] Contact your nearest Square D/Schneider Electric sales office for additional I/O options.

Now!

PowerLogic ION7400 Utility Feeder Meter

The PowerLogic ION7400 utility feeder meter is a highly accurate, extremely reliable power and energy meter with unmatched flexibility and usability. The meter combines accurate 3-phase energy and power measurements with data logging, power quality analysis, alarming and I/O capabilities not typically available in such a compact meter.

The panel or DIN mounted ION7400 meter is flexible enough to fit into a utility's existing billing or SCADA system, providing industry leading cost management (Class 0.2) and network management (Class S PQ) data. It is compliant with stringent international standards that guarantee their metering accuracy and power quality measurements. Ideal for installations that are responsible for maintaining the operation and profitability of a facility.



PowerLogic ION7400

Applications and benefits

- Maximize profits by providing the highest output possible with the least amount of risk to availability.
- Optimize availability and reliability of electrical systems and equipment.
- Monitor power quality (PQ) for compliance and to prevent problems.
- Meters fully supported by StruxureWare Power Monitoring Expert and PowerSCADA Expert Software.

Main Characteristics

- Precision metering
- PQ compliance reporting and basic PQ analysis
- Used with StruxureWare Power Monitoring Expert software, provides detailed PQ reporting across entire network
- Onboard data and event logging
- Alarming and control
- Excellent quality: ISO 9001 and ISO 14000 certified manufacturing.

Table 4.5: PowerLogic ION7400 Meters

Description	Catalog Number
ION7400 Panel mount meter (integrated display with optical port and 2 energy pulse LEDs)	METSEION7400
DIN rail mount - utility meter base	METSEION7403

Table 4.6: PowerLogic ION7400 Accessories

Description	Catalog Number
Remote display, 3 metre cable, mounting hardware for 30mm hole (nut & centering pin), mounting hardware for DIN96 cutout (92x92mm) adapter plate	METSEPM89RD96
Digital I/O module (6 digital inputs & 2 relay outputs)	METSEPM89M2600
Analog I/O module (4 analog inputs & 2 analog outputs)	METSEPM89M0024
Display Cable, 10 meters	METSECAB10



PowerLogic ION7400 showing active alarms.

PowerLogic ION7400 with harmonics display.

PowerLogic ION7400 with phasor display.

Table 4.7: PowerLogic ION7400 Features

Description	ION7400
General	
Use on LV and MV systems	■
Current accuracy (5A Nominal)	0.1 % reading
Voltage accuracy (90-690 V AC L-L, 50, 60, 400 Hz)	0.1 % reading
Active energy accuracy	0.2 %
Number of samples/cycle or sample frequency	256
Instantaneous rms values	
Current, voltage, frequency	■
Active, reactive, apparent power	Total and per phase
Power factor	Total and per phase
Current measurement range (autoranging)	0.05 - 10A
Energy values	
Active, reactive, apparent energy	■
Settable accumulation modes	■
Demand values	
Current	Present and max. values
Active, reactive, apparent power	Present and max. values
Predicted active, reactive, apparent power	■
Synchronisation of the measurement window	■
Setting of calculation mode	Block, sliding
Power quality measurements	
Harmonic distortion	Current and voltage
Individual harmonics	Via front panel and web page
Waveform capture	Via StruxurWare software
Detection of voltage swells and sags	127
Flicker	■
Fast acquisition	1/2 cycle data
EN 50160 compliance checking	■
Customizable data outputs (using logic and math functions)	■
Data recording	
Min/max of instantaneous values	■
Data logs	■
Event logs	■
Trending/forecasting	■
SER (Sequence of event recording)	■
Time stamping	■
GPS synchronization (+/- 1 ms)	■
Memory (in Mbytes)	512
	10 MB for Frameworks
Display and I/O	
Front panel display 89 mm (3.5 in.) TFT	■
Wiring self-test	■
Pulse output	1
Digital	6 in / 2 out
Analogue	4 in / 2 out
Digital or analogue outputs (max, including pulse output)	1 digital 8 relay 8 analog
Communication	
RS 485 port	1
10/100BaseTX	2
Serial port (Modbus, ION, DNP3)	■
Ethernet port (Modbus/TCP, ION TCP, DNP3 TCP, IEC 61850 [2])	■
ANSI C12.19 Optical port	■
Standards	
EC 61000-4-30, EC 61000-4-7, EC 61000-4-15, EC 61326-1, ANSI C12 20, IEC 62052-11, EC 62053-22, CLC/TR50579	

[2] All the communication ports may be used simultaneously.

Now!

PowerLogic PM8000 Power and Energy Meters

These compact meters help ensure the reliability and efficiency of your facility by making the management of power quality, availability, and reliability easy. Measure, understand, and act on insightful power and energy data gathered from your entire system.

The best choice for power management

PM8000 meters combine accurate 3-phase energy and power measurements with data logging, power quality analysis, alarming and I/O capabilities not typically available in such compact meters. Four-metered current inputs allow direct measurement of 3-phase currents and neutral current for enhanced view of harmonics. Dual Ethernet ports support daisy-chaining, removing need for an Ethernet switch inside power equipment, while redundant ring topology provides enhanced availability. Modular, field installable I/O provides expandable scalability. Patented ION technology combines convenient, pre-configured functionality with the ability to customize the meter configuration to meet unique requirements. This embedded capability can save the expense and complexity of additional equipment, both today and tomorrow. Plus, simple installation and networking make energy information quickly accessible, while integration with StruxureWare™ software and your energy management system make it immediately actionable.



Address power issues before they cause problems

- Monitor harmonics to mitigate excessive heating and premature failure of transformers
- Use trending and alarming to detect fluctuations in current pull of critical equipment to prevent motor failure
- Utilize millisecond time stamping to analyze sequence of events
- Identify root cause by analyzing electrical faults with patented disturbance direction detection
- Identify power quality issues per EN 50160, including frequency inconsistency, voltage fluctuations and unbalance, and harmonic contribution
- Allocate costs for water, air, gas, electricity, and steam (WAGES) across departments, phases of industrial process, or cost centers
- Utilize time-of-use calendar to capture electrical consumption for specific times, including on/off peak and holidays

Table 4.8: PM8000 Power and Energy Meter Catalog Numbers

Description	Catalog Number
PM8000 Panel Mount Meter with Integrated Display	METSEPM8240
PM8000 DIN Rail Mount Meter without Display	METSEPM8243
PM8000 DIN Rail Mount Meter + Remote Display	METSEPM8244
Remote Display, Color LCD, 96 x 96	METSEPM89RD96
I/O module, 2 relay outputs, 6 digital inputs	METSEPM89M2600
I/O module, 2 analog outputs, 4 analog inputs	METSEPM89M0024
Display Cable, 10 meters	METSECAB10
Display Cable, 3 meters	METSECAB3
Display Cable, 1 meters	METSECAB1
Sealing kit	METSEPM8000SK
Mounting adapter kit (ANSI 4")	METSEPM8AK
Replacement hardware kit, PM8000 meter	METSEPM8HWK
Replacement hardware kit, PM8000 remote display	METSEPM8RDHWK

Table 4.9: PM8000 Series Features

Intermediate meter		
General		
Use on LV and MV systems		■
Current accuracy (5A Nominal)		0.1 % reading
Voltage accuracy (57 V LN/100 V LL to 400 V LN/690 V LL)		0.1 % reading
Active energy accuracy		0.2 %
Number of samples/cycle or sample frequency		256
Instantaneous rms values		
Current, voltage, frequency		■
Active, reactive, apparent power	Total and per phase	■
Power factor	Total and per phase	■
Current measurement range (autoranging)		0.05–10 A
Energy values		
Active, reactive, apparent energy		■
Settable accumulation modes		■
Demand values		
Current	Present and max. values	■
Active, reactive, apparent power	Present and max. values	■
Predicted active, reactive, apparent power		■
Synchronization of the measurement window		■
Setting of calculation mode	Block, sliding	■
Power quality measurements		
Harmonic distortion	Current and voltage	■
Individual harmonics	Via front panel and web page	63
	Via StruxureWare software	127
Waveform capture		■
Detection of voltage swells and sags		■
Fast acquisition	1/2 cycle data	■
EN 50160 compliance checking		■
Customizable data outputs (using logic and math functions)		■
Data recording		
Min/max of instantaneous values		■
Data logs		■
Event logs		■
Trending/forecasting		
SER (Sequence of event recording)		■
Time stamping		■
GPS synchronization (+/- 1 ms)		■
Memory (in Mbytes)		512
Display and I/O		
Front panel display		■
Wiring self-test		■
Pulse output		1
Digital or analog inputs(max)		27 digital 16 analog
Digital or analog outputs (max, including pulse output)		1 digital 8 relay 8 analog
Communication		
RS 485 port		1
Ethernet ports		2
Serial port (Modbus, ION, DNP3)		■
Ethernet port (Modbus/TCP, ION TCP, DNP3 TCP, IEC 61850)		■
Ethernet gateway		■
Alarm notification via email		■
HTTP web server		■
SNMP with custom MIB and traps for alarms		■
SMTP email		■
NTP time synchronization		■
FTP File transfer		■

Power Quality Meter Selection

Features [3]	ION8650			ION7650	ION7550	CM4000T	ION7400	PM8000
	A	B	C					
Inputs, outputs and control power								
3-phase / single-phase	*/•	*/•	*/•	*/•	*/•	*/•	*/•	*/•
Digital in and out / analog in and out	16 / 4	16 / 4	16 / 4	20 / 8	20 / 8	24 / 4	36/24	36/24
Power supply options	AC/DC	AC/DC	AC/DC	AC/DC	AC/DC	AC/DC	AC/DC	AC/DC
Power and energy measurements								
Voltage, current, frequency, power factor	*	*	*	*	*	*	*	*
Power / Demand	*/•	*/•	*/•	*/•	*/•	*/•	*/•	*/•
Energy / time-of-use (energy per shift)	*/•	*/•	*/•	*/•	*/•	*/•	*/•	*/•
IEC / ANSI energy accuracy class (% of reading)	0.2(1)	0.2(1)	0.2(1)	0.2	0.2	0.2	0.2	0.2
Loss compensation	*	*	*	*	*	-	-	-
Power quality analysis								
EN50160 compliance reporting / IEC 61000-4-30 Class A or S	*/A	*/S	-/-	*/A	-/-	*/-	*/S	*/S
Flicker measurement	*	*	-	*	-	*	-	-
Transient detection duration	17 µs	-	-	17 µs	-	200 ns	-	-
Sag and swell monitoring / disturbance direction detection	*/-	*/-	*/-	*/•	*/•	*/•	*/•	*/•
Harmonic distortion: total/ individual / inter	*/••	*/•-	*/•-	*/••	*/•-	*/•-	*/•-	*/•-
Waveform capture	*	-	-	*	*	*	*	*
On-board data and event logging								
Trending / forecasting / billing	*/-•	*/-•	*/-•	*/••	*/••	*/••	*/••	*/••
Minimum and maximum	*	*	*	*	*	*	*	*
Events and alarms with timestamps	*	*	*	*	*	*	*	*
Timestamp resolution (seconds)	0.001	0.001	0.001	0.001	0.001	0.001	0.001	0.001
Time sync: Network / GPS / IREG-B / DCF77-B	*/•/-	*/•/-	*/•/-	*/•/-/-	*/•/-/-	*/•/-•	*/••/-	*/••/-
Setpoints, alarms and control								
Log alarm conditions / call out on alarm	*/•	*/•	*/•	*/•	*/•	*/•	*/•	*/•
Trigger data logging / waveform capture	*/•	*/-	*/-	*/•	*/•	*/•	*/•	*/•
Trigger relay or digital output	*	*	*	*	*	*	*	*
Special features								
Custom programming	*	*	*	*	*	*	*	*
Downloadable firmware	*	*	*	*	*	*	*	*
Communications								
Ports								
Ethernet: Copper / Fiber	*/•	*/•	*/•	*/•	*/•	*/•	2/-	2/-
Ethernet-to-serial gateway	*	*	*	*	*	*	2/-	*
Telephone modem	*	*	*	*	*	-	-	-
Modem-to-serial gateway	*	*	*	*	*	-	-	-
Infrared port	*	*/•	*/•	*/•	*/•	-	*	-
RS485/RS232	*/•	*/•	*/•	*/•	*/•	*/•	*/-	*/-
Misc: Web server / Email / SNMP / XML	*/•/-•	*/•/-•	*/•/-•	*/••/••	*/••/••	*/••/-•	*/••/••	*/••/••
Protocols: Modbus / DNP / MV-90 / DLMS	*/••/•-	*/••/•-	*/••/•-	*/••/•-	*/••/•-	*/••/•-	*/••/•-	*/••/•-
Protocols: IEC61850 / Jbus / M-Bus / LON / BACnet	*/-/-/-/-	*/-/-/-/-	*/-/-/-/-	*/-/-/-/-	*/-/-/-/-	-/-/-/-/-	*/-/-/-/-	*/-/-/-/-

NOTE:

1. The ION8650 is two times more accurate than the 0.2 IEC/ANSI accuracy classes according to the same conditions used to specify the 0.2 accuracy class.
2. ION8800, ION8650, ION8600, ION7650, ION7550, PM8000 also offer Modbus Master capabilities.

[3] Specifications represent maximum capabilities with all options installed. Some options are not available concurrently. This is not a complete feature list, please refer to detailed product specifications.



PM5000 Series Power Meter



PowerLogic ION6200 Series

Now!

Series 5000 Power Meters

The PowerLogic PM5000 series power meters are the new benchmark in affordable, precision metering. It is the ideal fit for high-end cost management applications, providing measurement capabilities needed to allocate energy usage, perform tenant metering and sub-billing, pin-point energy savings, optimize equipment efficiency and utilization, and perform a high level assessment of the power quality in electrical networks.

All meters provide Modbus serial communications. PM5500 level meters are also capable of simultaneous Modbus TCP and BTL-certified BACnet IP communications over Ethernet.

- Panel instrumentation (OEMs)
- Sub-billing and cost allocation
- Remote monitoring of an electrical installation
- Harmonic monitoring (THD)

Table 4.10: Series 5000 Power Meters

Description	Catalog No.
Power Meter, Class 0.5 Serial Port	METSEPM5110
Meter, Class 0.5 Alarms TOU Serial Port	METSEPM5330
Power Meter, Class 0.5 Alarms TOU Ethernet Port	METSEPM5340
Power Meter Class 0.2 Serial Port and Dual Ethernet	METSEPM5560
Power Meter without Display Class 0.2 Serial Port and Dual Ethernet	METSEPM5563
Remote Display for METSEPM5563	METSEPM5RDR
Power Meter with Remote Display Class 0.2 Serial Port and Dual Ethernet	METSEPM5563RD ^[4]

ION6200 Power and Energy Meter

The modular PowerLogic ION6200 is a low-cost, ultra-compact meter that offers outstanding versatility and functionality. It is simple to use, and has a big, bright LED display. It offers four-quadrant power, demand, energy, power factor and frequency measurements, and is available in a variety of flexible configurations. It is available as a low-cost base model to which enhanced functionality can be added over the long term. The PowerLogic ION6200 is ideal for customers who need revenue-accurate and/or certified measurements and want easy integration with power distribution assemblies and building automation systems. A Megawatt version is available for applications requiring readings in megawatts and kilovolts. It is well suited for sub-metering, energy cost tracking load profiling, and substation panel metering and is an ideal replacement for analog meters. It can be used for stand-alone metering in custom panels, switchboards, switchgear, gensets, motor control centers and UPS systems.

The meter consists of a base unit with options card and a power supply pack, with a remote display being optional.

PowerLogic ION6200 Power and Energy Meter Features

- Only two inches deep, and fits a standard ANSI four-inch switchboard cutout, or as a TRAN model with no display and can be fastened to a flat surface with a 4" (10cm) ANSI bolt pattern or mounted to a DIN rail. A remote display module (RMD) can be ordered for the TRAN and mounted through an ANSI 4" (10cm) and DIN 96 cutout.
- LED display with twelve 3/4" (19mm) high digits that display all basic power parameters
- Pulse Outputs: optional kWh, kVARh and/or kVAh pulsing
- Via two Form A outputs
- Communications: optional RS-485 port with Modbus RTU and ION compatible
- 64 samples per cycle true RMS
- 3-phase voltage and current inputs

The standard ION6200 is available with the following: Voltage L-N average and per phase, Voltage L-L average and per phase, Current average and per phase.

Option EP#1, includes the standard measurements and provides the following additional parameters: kW/mW total, kWh/mWh total, kW/mW peak, Current demand average and per phase, Current peak demand average and per phase, Power factor total.

Optional Enhanced Package, includes the standard measurements and provides the following additional parameters: kW/mW per phase, kVAR/mVAR total and per phase, kVA/mVA total and per phase, kWh/mWh and del/rec per phase, kVARh/mVARh total and del/rec per phase, kVAh/mVAh total and per phase, kW/mW demand, kVAR/mVAR demand and peak, kVA/mVA demand and peak, Power Factor per phase, Voltage THD per phase, Current THD per phase.

Table 4.11: Typical PowerLogic ION6200 Ordering Configurations

Description	Catalog No.
Integrated display, 10 A inputs, standard 100–240 Vac power supply, RS485 port (Modbus RTU), 2 pulse outputs, Enhanced Package #2	S6200A0A0B0A0B0R
TRAN Model, with remote display, 10 A inputs, standard 100–240 Vac power supply, RS485 port (Modbus RTU), 2 pulse outputs, Enhanced Package #2	S6200R1A0B0A0B0R
TRAN Model, (no display), 10 A inputs, standard 100–240 Vac power supply, RS485 port (Modbus RTU), 2 pulse outputs, Enhanced Package #2	S6200T1A0B0A0B0R

NOTE: Please refer to www.schneider-electric.us for the most complete and up-to-date list of feature availability. Some features are optional.

[4] METSEPM5563RD includes both METSEPM5563 and METSEPM5RDR.



EM3500 Series Energy and Power Meter

Series 3500 Energy and Power Meter

The EM3500 series Energy and Power Meter combines exceptional performance and easy installation to deliver a cost-effective solution for power monitoring applications. The EM3500 series can be installed on standard DIN rail or surface mounted, and has bi-directional monitoring designed expressly for renewable energy applications.

- Pulse output and phase alarms
- Data logging capability in some models
- Modbus and BACnet output options

Table 4.12: Series 3500 Energy and Power Meters

Description	Catalog Number
Power Meter, DIN-rail, Pulse Output Only, for LVCTs	METSEEM3502
Power Meter, DIN-rail Pulse Output Only, for U018 Rope CTs	METSEEM3502A
Power Meter, DIN-rail Modbus Output for LVCTs	METSEEM3550
Power Meter, DIN-rail, Modbus Output, for U018 Rope CTs	METSEEM3550A
Power Meter, DIN-rail Modbus Output, Bi-Directional, Logging for LVCTs	METSEEM3555
Power Meter, DIN-rail Modbus Output, Bi-Directional, Logging for U018 rope CTs	METSEEM3555A
Power Meter, DIN-rail, BACnet Output, Logging for LVCTs	METSEEM3560
Power Meter, DIN-rail, BACnet Output, Logging for U018 Rope CTs	METSEEM3560A
Power Meter, DIN-rail, BACnet Output, for LVCTs	METSEEM3561
Power Meter, DIN-rail, BACnet Output, for U018 Rope CTs	METSEEM3561A

U018 Series Rope-Style Current Transformers

The U018 series works exclusively with the EM3500A series power and energy meters. These meters have a built in power supply and integrator, so CT connecton is fast and simple. The coil opens at the connector juncton for fast and easy installaton onto an existng cable or buss-bar. The flexible core makes it easy to fit in tght enclosure

- Agency Approvals cURus, ANSI/IEEE 57.13, CE, RoHS
- Accuracy ±1% from 50 A to 5000 A
- Insulation up to 600 Vac

Description	Catalog Number
12 inch Rope CT for use with EM3500A DIN-Rail Meters, 50 A–5000 A, 1%, 8 ft. leads	U018-0001
18 inch Rope CT for use with EM3500A DIN-Rail Meters, 50 A–5000 A, 1%, 8 ft. leads	U018-0002
24 inch Rope CT for use with EM3500A DIN-Rail Meters, 50 A–5000 A, 1%, 8 ft. leads	U018-0003
36 inch Rope CT for use with EM3500A DIN-Rail Meters, 50 A–5000 A, 1%, 8 ft. leads	U018-0004
12 inch Rope CT for use with EM3500A DIN-Rail Meters, 50 A–5000 A, 1%, 12 ft. leads	U018-0005
18 inch Rope CT for use with EM3500A DIN-Rail Meters, 50 A–5000 A, 1%, 12 ft. leads	U018-0006
24 inch Rope CT for use with EM3500A DIN-Rail Meters, 50 A–5000 A, 1%, 12 ft. leads	U018-0007
36 inch Rope CT for use with EM3500A DIN-Rail Meters, 50 A–5000 A, 1%, 12 ft. leads	U018-0008

LVCT Series Current Transformers

LVCT current transducers provide a 0.333 V output for use with EM3500 series meters. Available in both solid and split core styles.

- Solid core accuracy ±0.5 of reading from 5% to 120% of rated current
- Split core accuracy 1% from 10% to 100% of rated current
- Leads 22 AWG, 600 Vac, UL 1015 bonded pair, 6 ft. (1.8 m) standard length

Description	Catalog Number
Split core	
Low-Voltage CT, Split Core, Size 0, 50 A:0.33 V	LVCT00050S
Low-Voltage CT, Split Core, Size 1, 100 A:0.33 V	LVCT00101S
Low-Voltage CT, Split Core, Size 2, 100 A:0.33 V	LVCT00102S
Low-Voltage CT, Split Core, Size 1, 200 A:0.33 V	LVCT00201S
Low-Voltage CT, Split Core, Size 2, 200 A:0.33 V	LVCT00202S
Low-Voltage CT, Split Core, Size 2, 300 A:0.33 V	LVCT00302S
Low-Voltage CT, Split Core, Size 3, 400 A:0.33 V	LVCT00403S
Low-Voltage CT, Split Core, Size 3, 600 A:0.33 V	LVCT00603S
Low-Voltage CT, Split Core, Size 3, 800 A:0.33 V	LVCT00803S
Low-Voltage CT, Split Core, Size 4, 800 A:0.33 V	LVCT00804S
Low-Voltage CT, Split Core, Size 4, 1000 A:0.33 V	LVCT01004S
Low-Voltage CT, Split Core, Size 4, 1200 A:0.33 V	LVCT01204S
Low-Voltage CT, Split Core, Size 4, 1600 A:0.33 V	LVCT01604S
Low-Voltage CT, Split Core, Size 4, 2000 A:0.33 V	LVCT02004S
Low-Voltage CT, Split Core, Size 4, 2400 A:0.33 V	LVCT02404S
Solid core	
Low-Voltage CT, Solid Core, Size 0, 50 A:0.33 V	LVCT20050S
Low-Voltage CT, Solid Core, Size 0, 100 A:0.33 V	LVCT20100S
Low-Voltage CT, Solid Core, Size 2, 200 A:0.33 V	LVCT20202S
Low-Voltage CT, Solid Core, Size 3, 400 A:0.33 V	LVCT20403S

Now!

PowerLogic PM3000 Power and Energy Meters

PM3000 series power meters are a cost-attractive, feature-rich range of DIN rail-mounted power meters that offers all the measurement capabilities required to monitor an electrical installation. Ideal for power metering and network monitoring applications that seek to improve the availability and reliability of your electrical distribution system, the meters are also fully capable of supporting sub billing and cost allocation applications. Four different models are available. Choose from models that provide Display Only, Display + Pulse Output, Display + Modbus, and Display + Modbus + DI/DO + Logging. All models use 1A/5A CTs.



PM3000 Series Power Meter

Table 4.13: PM3000 Features

Available Features	PM3200 Range			
	PM3200	PM3210	PM3250	PM3255
Performance Standard				
EC61557-12 PMD/Sx/K55/0 5	•	•	•	•
General				
Use on LV and HV systems	•	•	•	•
Number of samples per cycle	32	32	32	32
CT input 1A/5A	•	•	•	•
VT input	•	•	•	•
Multi-tariff	4	4	4	4
Multi-lingual backlit display	•	•	•	•
Instantaneous rms Values				
Current, voltage Per phase and average	•	•	•	•
Active, reactive, apparent power Total and per phase	•	•	•	•
Power factor Total and per phase	•	•	•	•
Energy Values				
Active, reactive and apparent energy; import and export	•	•	•	•
Demand Values				
Current, power (active, reactive, apparent) demand; present	•	•	•	•
Current, power (active, reactive, apparent) demand; peak		•	•	•
Power Quality Measurements				
THD Current and voltage		•	•	•
Data Recording				
Min/max of the instantaneous values	•	•	•	•
Power demand logs				•
Energy consumption log (day, week, month)				•
Alarms with time stamping		5	5	15
Digital inputs/digital outputs		0/1		2/2
Communication				
RS-485 port			•	•
Modbus protocol			•	•

Table 4.14: PM3000 Series Power Meters

Description	Catalog Number
PM3200 3PH energy meter, D N rail mount, 1A or 5A CT, Class 0.5S, no communications, MID compliant	METSEPM3200
PM3210 3PH energy meter, D N rail mount, 1A or 5A CT, Class 0.5S, pulse out, MID compliant, THD, one (1) DO	METSEPM3210
PM3250 3PH energy meter, D N rail mount, 1A or 5A CT, Class 0.5S, Modbus, THD	METSEPM3250
PM3255 3PH energy meter, D N rail mount, 1A or 5A CT, Class 0.5S, Modbus, M D compliant, THD, two (2) DI, two (2) DO	METSEPM3255

Now!

iEM3000 Energy Meters

The economical iEM3000 energy meters are ideal for helping facilities become more energy efficient. These feature-rich meters reduce installation and commissioning costs thanks to their efficient design and include native support for a variety of protocols, including Modbus, BACnet, LON, and M-Bus, for seamless integration into networks. Choose from models supporting a variety of current-sensing methods, including standard 1A/5A current transformers, 0.333 V low-voltage CTs, and U018 Rogowski coils. There are also direct connect models with internal current sensors that save installation time. The compact size is ideal for new and retrofit installations. Whether metering for energy awareness, billing, or advanced energy programs requiring full-featured, multi-tariff energy meters, there is an iEM3000 meter that fits the application.



iEM3000 Series Energy Meter

NOTE:

- For meter part number replace “i” in model name with “A9M”. (Example: iEM3150 = A9MEM3150)
- DIN rail housing size is 18mm x 5 width. (iEM33xx is 18mm x 7 width.)
- Digital input is selectable for Tariff control or WAGES
- Digital output is selectable for kWh pulse or kW alarm. (iEM3x10 is kWh pulse only.)

Measurement parameters

- Total and partial kWh shows consumption behavior
- Four-quadrant metering differentiates energy consumption
- Target green technologies (delivered/received)
- Reduce utility penalties (active/reactive)
- Additional parameters (P, Q, S, 3xI, V, PF, F) to monitor network balance and overload behavior

Smart Alarm

- kW overload alarm helps prevent utility demand charges

Table 4.15: iEM3000 Features

Function	Acti 9 iEM3000 Series Three-Phase Meters						
Current Input / Accuracy							
63A Direct / Class 1	iEM3100	iEM3110	iEM3135	iEM3150	iEM3155	iEM3165	iEM3175
1A or 5A CT / Class 0.5S	iEM3200	iEM3210	iEM3235	iEM3250	iEM3255	iEM3265	iEM3275
125A Direct / Class 1	iEM3300	iEM3310	iEM3335	iEM3350	iEM3355	iEM3365	iEM3375
0.333V or 1.0V LVCT / Class 0.5S					iEM3455	iEM3465	
Rogowski coil / Class 0.5S					iEM3555	iEM3565	
Protocol							
M-Bus			*				
Modbus				*	*		
BACnet						*	
LonWorks							*
Measurement							
M D compliant		*	*		*	*	*
4 quadrant energy			*		*	*	*
Multi Tariff							
Internal clock			4		4	4	4
External control		2			4	4	4
Digital I/O							
Number of inputs/outputs		-/1	1/1		1/1	1/1	1/1

Multiple Tariffs

- Save up to four different time slots to manage multiple tariffs (peak/off-peak, workday/weekend)
- Control tariffs via digital inputs, internal clock, or communication

Digital Inputs

- Use the meter as a pulse counter for another meter (WAGES monitoring)
- Manage double-source applications (e.g., utility main plus on-site generator)
- Monitor circuit breaker status or cabinet door opening

Digital Outputs

- Use to trip a light or sound an alarm
- Configure as a pulse output

Table 4.16: iEM3000 Series Energy Meters

Description	Catalog Number
iEM3100 3PH energy meter, DIN rail mount, direct connect 63A, Class 1	A9MEM3100
iEM3110 3PH energy meter, DIN rail mount, direct connect 63A, Class 1, pulse out, MID, one (1) DO	A9MEM3110
iEM3135 3PH energy meter, DIN rail mount, direct connect 63A, Class 1, M-Bus, M D, 4-quadrant energy, one (1) DI, one (1) DO	A9MEM3135
iEM3150 3PH energy meter, DIN rail mount, direct connect 63A, Class 1, Modbus	A9MEM3150
iEM3155 3PH energy meter, DIN rail mount, direct connect 63A, Class 1, Modbus, M D, 4-quadrant energy, one (1) DI, one (1) DO	A9MEM3155
iEM3165 3PH energy meter, DIN rail mount, direct connect 63A, Class 1, BACnet, MID, 4-quadrant energy, one (1) DI, one (1) DO	A9MEM3165
iEM3175 3PH energy meter, DIN rail mount, direct connect 63A, Class 1, LON, M D, 4-quadrant energy, one (1) DI, one (1) DO	A9MEM3175
iEM3200 3PH energy meter, DIN rail mount, 1A or 5A CT, Class 0.5S	A9MEM3200
iEM3210 3PH energy meter, DIN rail mount, 1A or 5A CT, Class 0.5S, pulse out, MID one (1) DO	A9MEM3210
iEM3235 3PH energy meter, DIN rail mount, 1A or 5A CT, Class 0.5S, M-Bus, MID, 4-quadrant energy, one (1) DI, one (1) DO	A9MEM3235
iEM3250 3PH energy meter, DIN rail mount, 1A or 5A CT, Class 0.5S, Modbus	A9MEM3250
iEM3255 3PH energy meter, DIN rail mount, 1A or 5A CT, Class 0.5S, Modbus, MID, 4-quadrant energy, one (1) DI, one (1) DO	A9MEM3255
iEM3265 3PH energy meter, DIN rail mount, 1A or 5A CT, Class 0.5S, BACnet, M D, 4-quadrant energy, one (1) DI, one (1) DO	A9MEM3265
iEM3275 3PH energy meter, DIN rail mount, 1A or 5A CT, Class 0.5S, LON, MID, 4-quadrant energy, one (1) DI, one (1) DO	A9MEM3275
iEM3300 3PH energy meter, DIN rail mount, direct connect 125A, Class 1	A9MEM3300
iEM3310 3PH energy meter, DIN rail mount, direct connect 125A, Class 1, pulse out, MID, one (1) DO	A9MEM3310
iEM3335 3PH energy meter, DIN rail mount, direct connect 125A, Class 1, M-Bus, MID, 4-quadrant energy, one (1) DI, one (1) DO	A9MEM3335
iEM3350 3PH energy meter, DIN rail mount, direct connect 125A, Class 1, Modbus	A9MEM3350
iEM3355 3PH energy meter, DIN rail mount, direct connect 125A, Class 1, Modbus, MID, 4-quadrant energy, one (1) DI, one (1) DO	A9MEM3355
iEM3365 3PH energy meter, DIN rail mount, direct connect 125A, Class 1, BACnet, MID, 4-quadrant energy, one (1) DI, one (1) DO	A9MEM3365
iEM3375 3PH energy meter, DIN rail mount, direct connect 125A, Class 1, LON, MID, 4-quadrant energy, one (1) DI, one (1) DO	A9MEM3375
iEM3455 3PH energy meter, DIN rail mount, LVCT, Class 0.5S, Modbus, M D, 4-quadrant energy, one (1) DI, one (1) DO	A9MEM3455
iEM3465 3PH energy meter, DIN rail mount, LVCT, Class 0.5S, BACnet, MID, 4-quadrant energy, one (1) DI, one (1) DO	A9MEM3465
iEM3555 3PH energy meter, DIN rail mount, Rogowski coil, Class 0.5S, Modbus, MID, 4-quadrant energy, one (1) DI, one (1) DO	A9MEM3555
iEM3565 3PH energy meter, DIN rail mount, Rogowski coil, Class 0.5S, BACnet, MID, 4-quadrant energy, one (1) DI, one (1) DO	A9MEM3565

Multiple Meter Unit Enclosures for iEM3000 Energy Meters

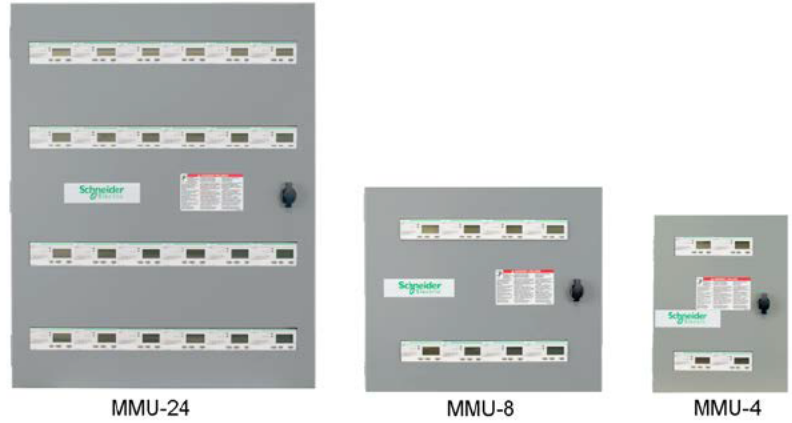

Schneider Electric's Multi-Meter Unit (MMU) enclosures are the ideal complement for the iEM3000 Series of energy meters. This compact solution saves wall space and is scalable for the exact number of meters required. Factory-assembled, pre-wired, and tested enclosures can speed installation, reduce the amount of field wiring, and save time troubleshooting.

Multi-meter unit enclosures and iEM3000 meters provide the highest quality, best value hardware for tenant sub-metering, and are designed for contractor convenience and simplicity.

MMU enclosures are available in three sizes:

- Small MMU enclosures with capacity for up to 4 iEM3000 meters.
- Medium size MMU enclosures with capacity for up to 8 iEM3000 meters, plus one gateway/data logger/energy server.
- Extra-large MMU enclosures with capacity for up to 24 iEM3000 meters, plus one gateway/ data logger/energy server.

Multi meter units are configured to order as described below.

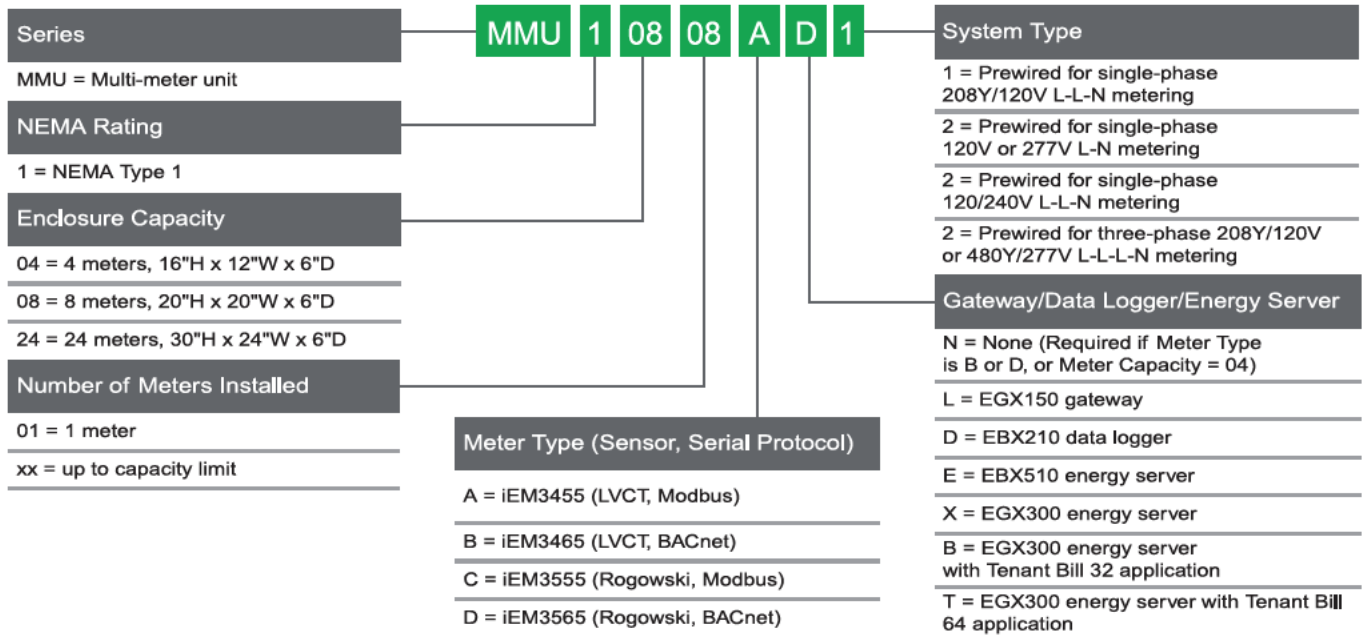

Power and Energy Meter Selection

Features [5]	PM5110	PM5330	PM5340	PM5500	ION6200	EM3500	PM3000	iEM3000
Inputs, outputs and control power								
3-phase / single-phase	*/•	*/•	*/•	*/•	*/•	*/•	*/•	*/•
Digital in and out / analog in and out	1/0	4/0	4/0	6/0	2/-	2 or 3/0	up to 2/2	up to 1/1
Power supply options	AC/DC	AC/DC	AC/DC	AC/DC	AC/DC	AC/DC	AC/DC	AC
Power and energy measurements								
Voltage, current, frequency, power factor	•	•	•	•	•	•	•	•
Power / Demand	*/•	*/•	*/•	*/•	*/•	*/•	*/•	*/-
Energy / time-of-use (energy per shift)	*/-	*/•	*/•	*/•	*/-	-/-	*/•	*/•
IEC / ANSI energy accuracy class (% of reading)	0.5	0.5	0.5	0.2	0.5	0.2	0.5	0.5
Loss compensation	-	-	-	-	-	-	-	-
Power quality analysis								
EN50160 compliance reporting / IEC 61000-4-30 Class A or S	-/-	-/-	-/-	-/-	-/-	-/-	-/-	-/-
Flicker measurement	-	-	-	-	-	-	-	-
Transient detection duration	-	-	-	-	-	-	-	-
Sag and swell monitoring / disturbance direction detection	-/-	-/-	-/-	-/-	-/-	-/-	-/-	-/-
Harmonic distortion: total/ individual / inter	*/•/-	*/•/-	*/•/-	*/•/-	*/•/-	-/-/-	*/•/-	-/-/-
Waveform capture	-	-	-	-	-	-	-	-
On-board data and event logging								
Trending / forecasting / billing	-/-/-	-/-/-	-/-/-	-/-/-	-/-/-	-/-/-	-/-/-	-/-/-
Minimum and maximum	•	•	•	•	•	•	•	•
Events and alarms with timestamps	-	•	•	•	-	-	•	-
Timestamp resolution (seconds)	1	1	1	1	-	1	1	-
Time sync: Network / GPS / IIRIG-B / DCF77-B	-/-/-/-	-/-/-/-	-/-/-/-	-/-/-/-	-/-/-/-	-/-/-/-	-/-/-/-	-/-/-/-
Setpoints, alarms and control								
Log alarm conditions / call out on alarm	-/-	*/•	*/•	*/•	-/-	-/-	*/-	-
Trigger data logging / waveform capture	-/-	-/-	-/-	-/-	-/-	-/-	-/-	-/-
Trigger relay or digital output	-	•	•	•	-	-	•	•
Special features								
Custom programming	-	-	-	-	-	-	-	-
Downloadable firmware	•	•	•	•	-	-	-	-
Communications								
Ports:								
Ethernet: Copper / Fiber	-/-	-/-	1/-	2/-	-/-	-/-	-/-	-/-
Ethernet-to-serial gateway	-	-	-	•	-	-	-	-
Telephone modem	-	-	-	-	-	-	-	-
Modem-to-serial gateway	-	-	-	-	-	-	-	-
Infrared port	-	-	-	-	-	-	-	-
RS485/RS232	*/-	*/-	-/-	*/-	*/-	*/-	*/-	*/-
Misc: Web server / Email / SNMP / XML	-/-/-/-	-/-/-/-	-/-/-/-	*/•/-/-	-/-/-/-	-/-/-/-	-/-/-/-	-/-/-/-
Protocols: Modbus / DNP / MV-90 / DLMS	*/•/-/-/-	*/•/-/-/-	*/•/-/-/-	*/•/-/-	*/•/-/-	*/•/-/-	*/•/-/-	*/•/-/-
Protocols: IEC61850 / Jbus / M-Bus / LON / BACnet	-/-/-/-/-	-/-/-/-/-	-/-/-/-/-	-/-/-/-/*	-/-/-/-/-	-/-/-/-/*	-/-/-/-/-	-/-/*/*/*

4 POWER MONITORING AND CONTROL

[5] Specifications represent maximum capabilities with all options installed. Some options are not available concurrently. This is not a complete feature list, please refer to detailed product specifications.



Energy Meter

Table 4.17: Basic 120/240 V to 208Y/120 V

Description	Catalog No.
Basic 100 A, 518"x1.28" D, 1 CT	EMB1010
Basic 200 A, 0.75" x 1.10" ID, 1 CT	EMB1021
Basic 300 A, 90"x1.90" ID, 1 CT	EMB1032
Basic 100 A, 518"x1.28" D, 2 CTs	EMB2010
Basic 200 A, 0.75" x 1.10" ID, 2 CTs	EMB2021
Basic 300 A, 90"x1.90" ID, 2 CTs	EMB2032
Basic 400 A, 2.45"x2.89" D, 2 CTs	EMB2043
Basic 800 A, 2.45"x2.89" D, 2 CTs	EMB2083
Basic 100 A, 518"x1.28" D, 3 CTs	EMB3010
Basic 200 A, 0.75" x 1.10" ID, 3 CTs	EMB3021
Basic 300 A, 90"x1.90" ID, 3 CTs	EMB3032
Basic 400 A, 2.45"x2.89" D, 3 CTs	EMB3043
Basic 800 A, 2.45"x2.89" D, 3 CTs	EMB3083
Basic 800 A, 2.45"x5.50" D, 3 CTs	EMB3084
Basic 1600 A, 2.45"x5.50" ID, 3 CTs	EMB3164

Table 4.19: Energy Meter Accessories

Description	Catalog No.
Energy Meter Communication Board [6]	EMCB
Energy Meter Fuse Pack, Set of 1	EMFP1
Energy Meter Fuse Pack, Set of 2	EMFP2
Energy Meter Fuse Pack, Set of 3	EMFP3
Energy Meter Bonding Kit	EMBOND

PowerLogic Energy Meter

The Energy Meter is ideal for stand-alone and systems-based submetering applications. It is easy to install and provides exceptional metering accuracy. Available in Basic and Extended Range models. The Basic model is designed for metering of 120/240 and 208Y/120 volt services. The Extended Range model will meter 120/240 volt up to 480 volt Wye connected services. Extended Range meters come with pulse output and phase loss output not available on the Basic unit. Optional Modbus™ RS-485 serial communications are provided with the Energy Meter Comms Board, EMCB. Optional kW demand is also provided by the EMCB.

Meter up to 3 individual services with one Energy Meter. The Energy Meter will allow the addition of up to 3 sets of parallel CTs for metering multiple electric loads. Additional sets of CTs can be ordered separately. Please refer to the multiple CT application notes in the Energy Meter instruction bulletin for the proper installation procedures.

Table 4.18: Extended Range 120/240 V to 480Y/277 V

Description	Catalog No.
Extended Range 100 A, .518"x1.28" ID, 1 CT	EME1010
Extended Range 200 A, 0.75" x 1.10" D, 1 CT	EME1021
Extended Range 300 A, .90"x1.90" D, 1 CT	EME1032
Extended Range 100 A, n.518"x1.28" ID, 2 CTs	EME2010
Extended Range 200 A, 0.75" x 1.10" D, 2 CTs	EME2021
Extended Range 300 A, .90"x1.90" D, 2 CTs	EME2032
Extended Range 400 A, 2.45"x2.89" ID, 2 CTs	EME2043
Extended Range 800 A, 2.45"x2.89" ID, 2 CTs	EME2083
Extended Range 100 A, .518"x1.28" ID, 3 CTs	EME3010
Extended Range 200 A, 0.75" x 1.10" D, 3 CTs	EME3021
Extended Range 300 A, .90"x1.90" D, 3 CTs	EME3032
Extended Range 400 A, 2.45"x2.89" ID, 3 CTs	EME3043
Extended Range 800 A, 2.45"x2.89" ID, 3 CTs	EME3083
Extended Range 800 A, 2.45"x5.50" ID, 3 CTs	EME3084
Extended Range 1600 A, 2.45"x5.50" ID, 3 CTs	EME3164

Table 4.20: Additional CT Sets

Description	Catalog No.
100 A, .518" x 1.28" ID, 1 CT	EMCT010
200 A, 0.75" x 1.10" ID, 1 CT	EMCT021
300 A, .90" x 1.90" D, 1 CT	EMCT032
400 A, 2.45" x 2.89" ID, 1 CT	EMCT043
800 A, 2.45" x 2.89" ID, 1 CT	EMCT083
800 A, 2.45" x 5.50" ID, 1 CT	EMCT084
1600 A, 2.45" x 5.50" ID, 1 CT	EMCT164

NOTE: CT quantity and amperage must match meter model. Total of combined loads must not exceed rating of meter. All additional CTs shipped with 6 ft. white and black color-coded wire leads.

Now!

PowerLogic EM4200 Enercept Meter

Next generation Enercept meters provide a unique solution for measuring energy data. The small form factor enables retrofit installation in existing panels to save wall space, installation time, and material cost. They are compatible with 0.333V LVCT split-core, solid-core and U018 rope-style current transducers 50–5000A and communicate using Modbus and BACnet protocols.

Features

- High reliability with ANSI C12.20 0.2% accuracy, IEC 62053-22 Class 0.2S, 90 to 480 Vac
- Compact size for easy in-panel mounting, DIN rail or screw mount options
- Easy integration with a variety of CT form factors – split-core, solid-core, and Rope-Style Rogowski (U018), and compatibility from 5 to 5000A
- Seamless integration with StruxureWare Power Monitoring Expert (PME), StruxureWare Building Operation (SBO), and StruxureWare Building Expert (SBE)
- Configurable with or without power
- Quick connection with auto protocol, baud rate, and uni-directional/bi-directional detection
- Native Modbus and BACnet protocols along with uni-directional and bi-directional feature sets in one unit

Table 4.21: EM4200 Enercept Meter

Description	Catalog Number
Enercept Power Meter, Class 0.2S, Modbus/BACnet RS485, ANSI wire code, compatible with LVCT and Rogowski coils, order separately	EM4236



EM4200 Series Enercept

[6] Energy Meter communication board (EMCB) can be used with all models of the Energy Meter. Order one EMCB for each Energy Meter where either kW demand and/or communication is specified.



Enercept Meter

PowerLogic Enercept™ Meter

The Enercept Meter is the ideal solution for submetering electric loads where space is at a premium. The compact design consists of three interconnected split-core CTs with the metering and communication electronics built into the CT housing. Simply snap on the CTs, connect the voltage inputs, the communication lines, and installation is complete. Both versions can be connected to either three-phase or single-phase circuits.

Enercept meters employ the Modbus™ RTU 2-wire communication protocol, and can utilize the same communication network and Power Management Software applications as other PowerLogic devices. Data from the Enercept meters can be presented in tabular or graphical format, used for alarming and historical logging and trending, and to produce reports.

Optional Submeter display (SMD) acts as a stand-alone operator interface supporting up to 32 meters (63 with a repeater). In addition, the Submeter display (SMD) can act as a network adapter allowing Enercept meters to be incorporated into a network.

Table 4.22: Enercept Meter

Description	Catalog No.
Basic 100 A, 1.25" x 1.51" ID	3020B012 [7]
Basic 300 A, 1.25" x 1.51" ID	3020B032 [7]
Basic 400 A, 2.45" x 2.89" ID	3020B043 [7]
Basic 800 A, 2.45" x 2.89" ID	3020B083 [7]
Basic 800 A, 2.45" x 5.50" ID	3020B084 [7]
Basic 1600 A, 2.45" x 5.50" D	3020B164 [7]
Basic 2400 A, 2.45" x 5.50" D	3020B244 [7]
Enhanced 100 A, 1.25" x 1.51" D	3020E012
Enhanced 300 A, 1.25" x 1.51" D	3020E032
Enhanced 400 A, 2.45" x 2.89" D	3020E043
Enhanced 800 A, 2.45" x 2.89" D	3020E083
Enhanced 800 A, 2.45" x 5.50" D	3020E084
Enhanced 1600 A, 2.45" x 5.50" ID	3020E164
Enhanced 2400 A, 2.45" x 5.50" ID	3020E244

Table 4.23: Accessories

Description	Catalog No.
Submeter display mounted in enclosure	SMD
Open style submeter display, no enclosure	SMD OPN
2-Wire 232–485 Conv	30502W485C
Enercept Mounting Brackets (Set of 3)	3050EMBK-3

Table 4.24: Enercept Metering Quantities

Basic [7]	Enhanced
kWh, energy usage kW, real power	kWh, kW per phase and total, min kW, max kW, kWd, kVAR, kVA, PF per phase and total voltage-V, L-L, L-N per phase and avg. Current - A, per phase and average

PowerLogic Instrument Grade 5 Amp Split-Core Current Transformers

The 3090 SCCT series of split-core current transformers provide secondary amperage proportional to the primary (sensed) current. For use with Circuit Monitors, Power Meters, data loggers, chart recorders and other instruments the 3090 SCCT series provides a cost-effective means to transform electrical service amperages to a 0–5A level compatible with monitoring equipment.



SA Split-Core Current Transformers

Table 4.25:

Description	Catalog No.
Split Core CT—200 A (sz.2): 1.25" x 1.51	3090SCCT022
Split Core CT—300 A (sz.2): 1.25" x 1.51	3090SCCT032
Split Core CT—400 A (sz.3): 2.45" x 2.89	3090SCCT043
Split Core CT—600 A (sz.3): 2.45" x 2.89	3090SCCT063
Split Core CT—800 A (sz.3): 2.45" x 2.89	3090SCCT083
Split Core CT—800 A (sz.4): 2.45" x 5.05	3090SCCT084
Split Core CT—1200 A (sz.4): 2.45" x 5.50	3090SCCT124
Split Core CT—1600 A (sz.4): 2.45" x 5.50	3090SCCT164

NOTE: Max. Voltage without additional insulation 600 Vac. Do not apply 600 V Class current transformers to circuits having a phase-to-phase voltage greater than 600 V, unless adequate additional insulation is applied between the primary conductor and the current transformers. Square D assumes no responsibility for damage of equipment or personal injury caused by transformers operated on circuits above their published ratings.

[7] See Handout / Instruction Bulletin for derating properties.

Multi Circuit Energy Meters

The PowerLogic EM4800 and EM4000 multi-circuit energy meters combine accurate electricity sub-metering with advanced communications technology. They are ideal for multi-tenant or departmental metering and M&V applications within office towers, condominiums, apartment buildings, shopping centers and other multipoint environments, or small footprint retail. This meter is available separately or as part of a Square D integrated power center (IPC) for use in building retrofits or new construction.

Each compact multipoint meter provides energy measurement for up to 24 (1CT) or 12 (2CT) single-phase circuits or 8 (3CT) 3-phase circuits. Select a model to match the desired CT type. The 0.333 V output CT option does not require shorting blocks, making it the ideal choice for retrofit installations.

All meters have an accuracy of Class 0.5%, have onboard interval logging, and feature flexible communication options with an Ethernet port that supports multiple protocols: Modbus TCP/IP, HTTP, BACnet/IP, FTP, and SNMP. EM4800 series meters have a V.90 modem while EM4000 series meters provide Modbus RTU over RS-485.

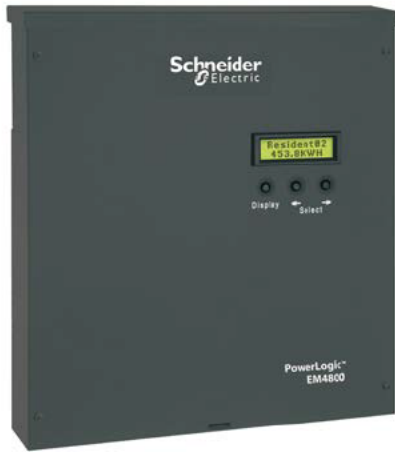
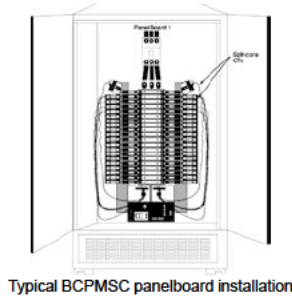
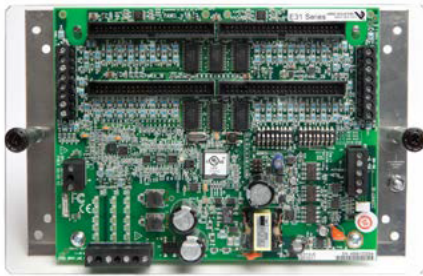

Table 4.26: Multi Circuit Energy Meters

Description	Catalog No.
EM4800 series; Ethernet; modem; compatible with 80mA low-power CTs; 120V control power 60 Hz	METSEEM488016
EM4800 series; Ethernet; modem; compatible with 333mV low-power CTs; 120V control power 60 Hz	METSEEM483316
EM4800 series; Ethernet; modem; compatible with standard 5A CTs; 120V control power 60 Hz	METSEEM480516
EM4000 series; Ethernet; Modbus RTU over RS-485; compatible with 80mA low-power CTs; 120V control power 60 Hz	METSEEM408016
EM4000 series; Ethernet; Modbus RTU over RS-485; compatible with 80mA low-power CTs; 277V control power 60 Hz	METSEEM408036
EM4000 series; Ethernet; Modbus RTU over RS-485; compatible with 333mV low-power CTs; 120V control power 60 Hz	METSEEM403316
EM4000 series; Ethernet; Modbus RTU over RS-485; compatible with 333mV low-power CTs; 277V control power 60 Hz	METSEEM403336
200 A current transformer (CT), 80 mA secondary, solid-core (1 CT)	METSECT80200
400 A current transformer (CT), 80 mA secondary, solid-core (1 CT)	METSECT80400
600 A current transformer (CT), 80 mA secondary, solid-core (1 CT)	METSECT80600
50 A .333 V Split Core Current Transformer with 0.75 in Window Size	ECT075050SC
100 A .333 V Split Core Current Transformer with 0.75 in Window Size	ECT075100SC
150 A .333 V Split Core Current Transformer with 0.75 in Window Size	ECT075150SC
200 A .333 V Split Core Current Transformer with 0.75 in Window Size	ECT075200SC
100 A .333 V Split Core Current Transformer with 1.25 in Window Size	ECT125100SC
150 A .333 V Split Core Current Transformer with 1.25 in Window Size	ECT125150SC
200 A .333 V Split Core Current Transformer with 1.25 in Window Size	ECT125200SC
400 A .333 V Split Core Current Transformer with 1.25 in Window Size	ECT125400SC
200 A .333 V Split Core Current Transformer with 2.00 in Window Size	ECT200200SC
400 A .333 V Split Core Current Transformer with 2.00 in Window Size	ECT200400SC
600 A .333 V Split Core Current Transformer with 2.00 in Window Size	ECT200600SC
600 A .333 V Split Core Current Transformer with 3 x 5 in Window Size	ECT300600SC
800 A .333 V Split Core Current Transformer with 3 x 5 in Window Size	ECT300800SC



Typical BCPMSC panelboard installation

PowerLogic Branch Circuit Power Meter

The ideal solution for data center managers, energy or facility managers, engineers and operational executives who are responsible for delivering power to critical applications. In corporate and hosted data center facilities, this technology helps you plan and optimize the critical power infrastructure to meet the demands of continuous availability.

The PowerLogic BCPM is a highly accurate, full-featured metering product designed for the unique, multi-circuit and minimal space requirements of a high performance power distribution unit (PDU) or remote power panel (RPP). It offers class 1 (1%) power and energy system accuracy (including 50 A or 100 A CTs) on all branch channels.

The BCPM monitors up to 84 branch circuits with a single device and also monitors the incoming power mains to provide information on a complete PDU. It also offers multi-phase measurement totals with flexible support for any configuration of multi-phase breakers. Full alarming capabilities ensure that potential issues are dealt with before they become problems.

Unlike products designed for specific hardware, the flexible BCPM will fit any PDU or RPP design and supports both new and retrofit installations. It has exceptional dynamic range and accuracy, and optional feature sets to meet the energy challenges of mission critical data centers.

Key Features:

- Integrated Ethernet with advanced SNMP, BACnet, and Modbus TCP support on BCPME models
- Class 1% system accuracy (including 50 A or 100 A branch CTs)
- Flexible configuration of Logical Meters for multi-phase loads
- Full PDU monitoring
- Flexible configuration
- Split core version for retrofit installations
- Wide monitoring range
- Low current monitoring
- Advanced alarming
- Easily integrates into a PowerLogic system or other existing networks using Modbus™ communications

Table 4.27: BCPM with Solid-Core CTs

Description	Catalog Number
42-circuit solid-core power & energy meter, 100A CTs (2 strips), ¾ in. spacing	BCPMA042S
84-circuit solid-core power & energy meter, 100A CTs (4 strips), ¾ in. spacing	BCPMA084S
42-circuit solid-core power & energy meter, 100A CTs (2 strips), 1 in. spacing	BCPMA142S
84-circuit solid-core power & energy meter, 100A CTs (4 strips), 1 in. spacing	BCPMA184S
24-circuit solid-core power & energy meter, 100A CTs (2 strips), 18 mm spacing	BCPMA224S
36-circuit solid-core power & energy meter, 100A CTs (2 strips), 18 mm spacing	BCPMA236S
42-circuit solid-core power & energy meter, 100A CTs (2 strips), 18 mm spacing	BCPMA242S
48-circuit solid-core power & energy meter, 100A CTs (4 strips), 18 mm spacing	BCPMA248S
72-circuit solid-core power & energy meter, 100A CTs (4 strips), 18 mm spacing	BCPMA272S
84-circuit solid-core power & energy meter, 100A CTs (4 strips), 18 mm spacing	BCPMA284S
42-circuit solid-core branch current, mains power meter, 100A CTs (2 strips), ¾ in. spacing	BCPMB042S
84-circuit solid-core branch current, mains power meter, 100A CTs (4 strips), ¾ in. spacing	BCPMB084S
42-circuit solid-core branch current, mains power meter, 100A CTs (2 strips), 1 in. spacing	BCPMB142S
84-circuit solid-core branch current, mains power meter, 100A CTs (4 strips), 1 in. spacing	BCPMB184S
24-circuit solid-core branch current, mains power meter, 100A CTs (2 strips), 18 mm spacing	BCPMB224S
36-circuit solid-core branch current, mains power meter, 100A CTs (2 strips), 18 mm spacing	BCPMB236S
42-circuit solid-core branch current, mains power meter, 100A CTs (2 strips), 18 mm spacing	BCPMB242S
48-circuit solid-core branch current, mains power meter, 100A CTs (4 strips), 18 mm spacing	BCPMB248S
72-circuit solid-core branch current, mains power meter, 100A CTs (4 strips), 18 mm spacing	BCPMB272S
84-circuit solid-core branch current, mains power meter, 100A CTs (4 strips), 18 mm spacing	BCPMB284S
42-circuit solid-core branch current meter, 100A CTs (2 strips), ¾ in. spacing	BCPMC042S
84-circuit solid-core branch current meter, 100A CTs (4 strips), ¾ in. spacing	BCPMC084S
42-circuit solid-core branch current meter, 100A CTs (2 strips), 1 in. spacing	BCPMC142S
84-circuit solid-core branch current meter, 100A CTs (4 strips), 1 in. spacing	BCPMC184S
24-circuit solid-core branch current meter, 100A CTs (2 strips), 18 mm spacing	BCPMC224S
36-circuit solid-core branch current meter, 100A CTs (2 strips), 18 mm spacing	BCPMC236S
42-circuit solid-core branch current meter, 100A CTs (2 strips), 18 mm spacing	BCPMC242S
48-circuit solid-core branch current meter, 100A CTs (4 strips), 18 mm spacing	BCPMC248S
72-circuit solid-core branch current meter, 100A CTs (4 strips), 18 mm spacing	BCPMC272S
84-circuit solid-core branch current meter, 100A CTs (4 strips), 18 mm spacing	BCPMC284S
42-circuit solid-core power & energy meter w/Ethernet, 100A CTs (2 strips), ¾ in. spacing	BCPME042S
84-circuit solid-core power & energy meter w/Ethernet, 100A CTs (4 strips), ¾ in. spacing	BCPME084S
42-circuit solid-core power & energy meter w/Ethernet, 100A CTs (2 strips), 1 in. spacing	BCPME142S
84-circuit solid-core power & energy meter w/Ethernet, 100A CTs (4 strips), 1 in. mm spacing	BCPME184S
24-circuit solid-core power & energy meter w/Ethernet, 100A CTs (2 strips), 18 mm spacing	BCPME224S
36-circuit solid-core power & energy meter w/Ethernet, 100A CTs (2 strips), 18 mm spacing	BCPME236S
42-circuit solid-core power & energy meter w/Ethernet, 100A CTs (2 strips), 18 mm spacing	BCPME242S
48-circuit solid-core power & energy meter w/Ethernet, 100A CTs (4 strips), 18 mm spacing	BCPME248S
72-circuit solid-core power & energy meter w/Ethernet, 100A CTs (4 strips), 18 mm spacing	BCPME272S
84-circuit solid-core power & energy meter w/Ethernet, 100A CTs (4 strips), 18 mm spacing	BCPME284S

Table 4.28: BCPM with Split-Core CTs

Description	Catalog Number
42-circuit split-core power and energy meter, CTs and cables sold separately	BCPMSCA1S
84-circuit split-core power and energy meter, CTs and cables sold separately	BCPMSCA2S
30-circuit split-core power and energy meter, (30) 50A CTs & (2) 4 ft. cables	BCPMSCA30S
42-circuit split-core power and energy meter, (42) 50A CTs & (2) 4 ft. cables	BCPMSCA42S
60-circuit split-core power and energy meter, (60) 50A CTs & (4) 4 ft. cables	BCPMSCA60S
42-circuit split core power and energy meter, all boards on backplate, CTs and cables sold separately	BCPMSCAY63S
84-circuit split-core power and energy meter, with (84) 50A CTs & (4) 4 ft. cables	BCPMSCA84S
42-circuit split-core branch current, mains power meter, CTs and cables sold separately	BCPMSCB1S
84-circuit split-core branch current, mains power meter, CTs and cables sold separately	BCPMSCB2S
30-circuit split-core branch current, mains power meter, (30) 50A CTs & (2) 4 ft. cables	BCPMSCB30S
42-circuit split-core branch current, mains power meter, (42) 50A CTs & (2) 4 ft. cables	BCPMSCB42S
60-circuit split-core branch current, mains power meter, (60) 50A CTs & (4) 4 ft. cables	BCPMSCB60S
42-circuit split-core branch current, mains, all boards on backplate, CTs and cables sold separately	BCPMSCBY63S
84-circuit split-core branch current, mains power meter, (84) 50A CTs & (4) 4 ft. cables	BCPMSCB84S
42-circuit split-core current meter, CTs and cables sold separately	BCPMSCC1S
84-circuit split-core current meter, CTs and cables sold separately	BCPMSCC2S
30-circuit split-core current meter, (30) 50A CTs & (2) 4 ft. cables	BCPMSCC30S
42 circuit split-core current meter, (42) 50A CTs & (2) 4 ft. cables	BCPMSCC42S
60-circuit split-core current meter, (60) 50A CTs & (4) 4 ft. cables	BCPMSCC60S
42-circuit split-core current meter, all boards on backplate, CTs and cables sold separately	BCPMSCCY63S
84-circuit split-core current meter, (84) 50A CTs & (4) 4 ft. cables	BCPMSCC84S
42-circuit split-core power and energy meter w/Ethernet, CTs and cables sold separately	BCPMSC1E1S
84-circuit split-core power and energy meter w/Ethernet, CTs and cables sold separately	BCPMSC1E2S
30-circuit split-core power and energy meter w/Ethernet, (30) 50A CTs & (2) 4 ft. cables	BCPMSC1E30S
42-circuit split-core power and energy meter w/Ethernet, (42) 50A CTs & (2) 4 ft. cables	BCPMSC1E42S
60-circuit split-core power and energy meter w/Ethernet, (60) 50A CTs & (4) 4 ft. cables	BCPMSC1E60S
84-circuit split-core power and energy meter w/Ethernet, (84) 50A CTs & (4) 4 ft. cables	BCPMSC1E84S

Table 4.29: 1/3 V Low-Voltage Split-Core CTs for Aux Inputs (Mains)

Amperage Rating	Inside Dimensions	Catalog Number
50A	10 x 11 mm	LVCT00050S
200A	16 x 20 mm	LVCT00101S
200A	32 x 32 mm	LVCT00202S
100A	30 x 31 mm	LVCT00102S
200A	30 x 31 mm	LVCT00202S
300A	30 x 31 mm	LVCT00302S
400A	62 x 73 mm	LVCT00403S
600A	62 x 73 mm	LVCT00603S
800A	62 x 73 mm	LVCT00803S
800A	62 x 139 mm	LVCT00804S
1000A	62 x 139 mm	LVCT01004S
1200A	62 x 139 mm	LVCT01204S
1600A	62 x 139 mm	LVCT01604S
2000A	62 x 139 mm	LVCT02004S
2400A	62 x 139 mm	LVCT02404S

Table 4.30: 1/3 V Low-Voltage Solid-Core CTs for Aux Inputs (Mains)

Amperage Rating	Inside Dimensions	Catalog Number
50A	10 mm	LVCT20050S
100A	10 mm	LVCT20100S
200A	25 mm	LVCT20202S
400A	31 mm	LVCT20403S

Table 4.31: BCPM Split-Core Branch CTs and Adapter Boards

Description	Catalog Number
BCPM adapter boards, quantity 2, for split core BCPM	BCPMSCADPBS
BCPM 50A split core CTs, Quantity 6, 1.8 m lead lengths	BCPMSCCT0
BCPM 50A split core CTs, quantity 6, 6 m lead lengths	BCPMSCCT0R20
BCPM 100A split core CTs, Quantity 6, 1.8 m lead lengths	BCPMSCCT1
BCPM 100A split core CTs, Quantity 6, 6 m lead lengths	BCPMSCCT1R20
BCPM 200A split core CTs, Quantity 1, 1.8 m lead lengths	BCPMSCCT3
BCPM 200A split core CTs, Quantity 1, 6 m lead lengths	BCPMSCCT3R20

Table 4.32: Additional Accessories for use with BCPM Products

Description	Catalog Number
BCPM circuit board cover	BCPMCOVERS
CT repair kit for solid core BCPM (includes one CT)	BCPMREPA R
Additional 100A split core CT for use with solid core repair kit	H6803R-0100
Modbus to BACnet protocol converter	E8951
Flat Ribbon cable (quantity 1) for BCPM, length = 0.45 m	CBL008
Flat Ribbon cable (quantity 1) for BCPM, length = 1.2 m	CBL016
Flat Ribbon cable (quantity 1) for BCPM, length = 1.5 m	CBL017
Flat Ribbon cable (quantity 1) for BCPM, length = 1.8 m	CBL018
Flat Ribbon cable (quantity 1) for BCPM, length = 2.4 m	CBL019
Flat Ribbon cable (quantity 1) for BCPM, length = 3.0 m	CBL020
Flat Ribbon cable (quantity 1) for BCPM, length = 6.1 m	CBL021
Round Ribbon cable (quantity 1) for BCPM, length = 1.2 m	CBL022
Round Ribbon cable (quantity 1) for BCPM, length = 3 m	CBL023
Round Ribbon cable (quantity 1) for BCPM, length = 6.1 m	CBL024
Round Ribbon cable (quantity 1) for BCPM, length = 0.5 m	CBL031
Round Ribbon cable (quantity 1) for BCPM, length = 0.8 m	CBL033

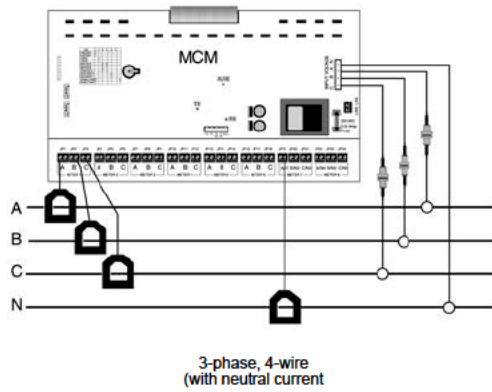

PowerLogic Multi-Circuit Meter

Designed for OEM style placement in electrical distribution equipment the MCM8364 is configurable to meter 1 or 3 phases of up to eight individual loads, six loads if neutral monitoring is required. The MCM will monitor up to 10,000 amps per service using standard 5 Amp CTs. All of the metered circuits must share a common voltage source. The MCM8364 is a great solution for monitoring critical power distribution equipment and provides 24 different electrical metering quantities plus an additional nine Modbus register alarms.

With one RS-485 connection, the multi-circuit meter provides Modbus RTU communications output that communicates to each individual metered circuit. Up to 30 multi-circuit meters can be addressed on the same Modbus network. The multi-circuit meter can provide warnings to the central monitoring computer via its Modbus output using the MNode software provided or can be integrated into PowerLogic SMS software. The MCM also works with the submeter display as shown below.

Electrical Data:

Energy Consumption (kWhr), Real Power (kW), Reactive Power (kVAR), Apparent Power (kVA), Power Factor Total, Voltage, L-L, avg. of 3 phases, Voltage, L-N, avg. of 3 phases, Current, average of 3 phases, Real Power (kW) phase A, B, & C, Power Factor, phase A, B, & C, Line to Line Voltage, phase A-B, B-C, A-C, Line to Neutral Voltage, phase A-N, B-N, C-N, Current, phase A, B, & C, Frequency (measured from phase A) (Hz).

Modbus Alarms:

Over Voltage, Under Voltage, Over Current, Under Current, Over kVA, Under kVA, Phase Loss A, Phase Loss B, Phase Loss C

Table 4.33:

Description	Catalog No.
Multi-Circuit Meter 8364	MCM8364

PowerLogic Submeter Display

The PowerLogic Submeter Display (SMD) is a comprehensive electrical submetering display that provides a view of electrical parameters from multiple metering products with one networked LCD. In addition to viewing system data on the display itself, you can also view data on a remote PC via a network connection. Touch pad buttons provide a convenient way to view downstream devices on the power-monitoring network. The display is RS-485 Modbus RTU compatible. It has additional RS-485 and RS-232 Modbus ports for networking to additional displays or to a master PC. The submeter display is compatible with the following metering devices: BCM, BCPM, EM3500, MCM, & Enercept™ meters.

Table 4.34:

Description	Catalog No.
Submeter display mounted in enclosure	SMD
Open style submeter display, no enclosure	SMD OPN



Submeter Display

New!

Com'X Data Loggers and Energy Servers

Powerful data logging with flexible communication options

Connect your entire power system with Com'X data loggers and energy servers. Com'X surpasses conventional gateways and data loggers by incorporating multiple capabilities into one compact device. In addition to being a real-time gateway to downstream devices, Com'x logs all essential WAGES and environmental readings through a broad range of downstream data feeds and local I/O. Logged data can be automatically pushed to a hosted platform or downloaded for report generation. Ethernet and Wi-Fi ready, Com'x leverages on the building's existing IT infrastructure to reduce cost. Its GPRS capability makes it ideal for sites with no access to IT networks.

Easy configuration and commissioning

Configuration and commissioning is made easy by automatic device detection, and IP address setting and allocation. No additional software is needed for the intuitive, web-based configuration pages. A device library enables quick configuration for more than 70 Modbus devices and also provides for custom configuration of additional devices. Configuration via Wi-Fi lets technicians use tablets or notebooks to work comfortably away from switchboard rooms.

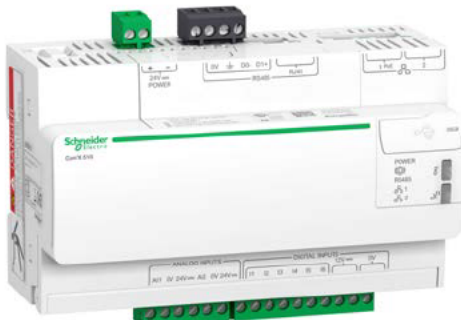

Com'X 510 Energy Server

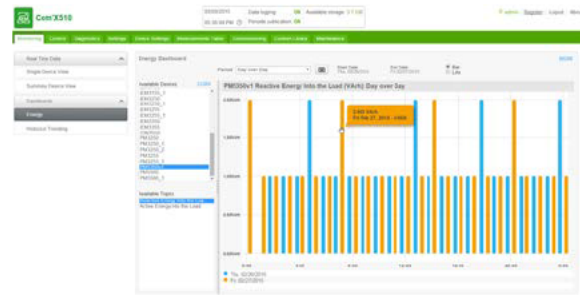

Com'X 510 Energy Dashboard

Embedded energy management software

The Com'X 510 Energy Server further includes embedded web pages that display data in a meaningful way so you can make informed decisions about your energy usage. Web pages display real-time data in easy to understand tabular and summary formats. In addition, you can access simple analysis of historical data in bar graph or trending formats. Pages are accessible via any standard web browser without plug-ins or additional components.

Table 4.35: Com'X Data Loggers, Energy Services, and Accessories

Description	Catalog Number
Com'X200 Data logger with internal 100 to 230 VAC power supply	EBX200
Com'X210 Data logger, requires 24 VDC power supply	EBX210
Com'X510 Energy server, requires 24 VDC power supply	EXB510
Wi-Fi USB stick	EBXAUSBWIFI
Zigbee USB stick	EXBAUSBZIGBEE
GPRS modem with S M card	EBXAGPRSSIM
GPRS modem without SIM card	EBXAGPRS
External GPRS antenna	EBXAANT5M



Link150 Ethernet Gateway

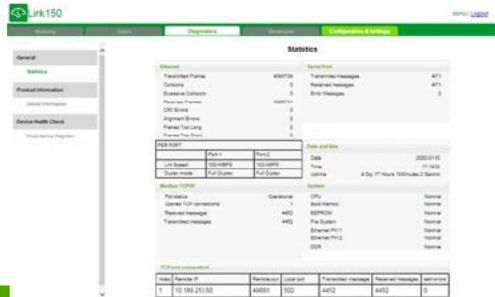

Link150 has embedded web pages for easy setup and maintenance

4

POWER MONITORING AND CONTROL

Link150 Ethernet Gateway

Communications for high-speed access to critical information

The Link150 gateway provides fast, reliable Ethernet connectivity in the most demanding applications, from a single building to a multi-site enterprise. This gateway supports meters, monitors, protective relays, trip units, motor controls and other devices that need to communicate data quickly and efficiently. It is your simple, cost-effective serial line to full Ethernet connectivity.

Applications

- Energy management
- Power distribution
- Building automation
- Factory automation

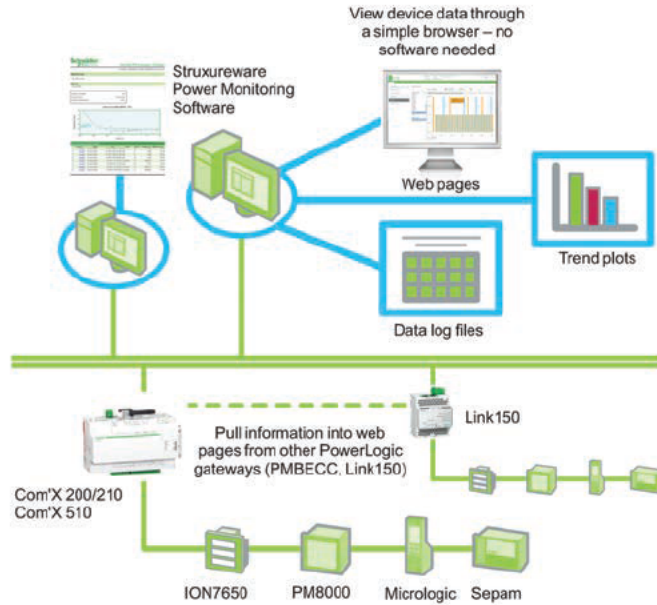

Security

- Secure user interface including user's name and password for login
- Advanced security features to allow users to specify which Modbus TCP/IP master devices may access attached serial slave devices
 - Modbus TCP/IP filtering feature
 - Allows user to specify the level of access for each master device as Read-only or Full access
- Web pages provide easy configuration and setup

Advantages

- Easy to install and setup
- Easy to maintain
- Compatible with Schneider Electric software offerings (StruxureWare Power Monitoring Expert, StruxureWare PowerSCADA Expert, etc.)
- Compatible with Com'X 200/210 and Com'X 510 Energy Servers
- Reliable Modbus to Ethernet protocol conversion

Table 4.36: Ethernet Gateway

Type	Catalog Number
Link150 Ethernet gateway	EGX150
Modbus 3 m cable RJ-45 to free wires	VW3A8306D30



Modbus 3 m cable RJ-45 to free wires

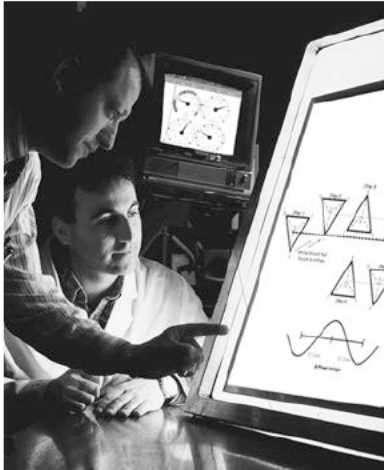

Consulting and Analysis

Power System Engineering

The Square D Power System Engineering team offers a wide range of engineering services to improve the safety, efficiency and reliability of your power distribution system. The team is comprised of registered professional engineers, safety trained and equipped, to perform a variety of engineering functions.

Power System Studies

The Square D Power System Engineering Team provides expertise for a variety of electrical power system studies. Some of the more common system studies include...

- Short-circuit analysis
- Time-current coordination
- Motor starting/voltage drop
- Motor starting/torque-speed
- Safe motor re-energization
- Harmonic analysis
- Transient analysis
- Power factor correction analysis
- Other system specific analysis

Arc Flash Analysis

Square D offers on-site services to perform arc flash analysis for a facility, complex, office, or campus. An Arc flash analysis is used to determine ...

- Flash Protection Boundary
- Incident Energy Value
- Hazard/Risk Category
- Appropriate Personal Protective Equipment (PPE)
- Low cost arc flash reduction methods

Features of Square D arc flash analysis include...

- Time current coordination analysis showing both existing and recommended over/current device settings
- Short-circuit study to ensure adequacy of equipment
- Onsite verification and documentation of equipment
- Arc flash labels (populated with the results of the arc flash analysis)
- Arc flash label affixation
- NFPA 70E—Safe Workplace Practices Training provided by OSHA authorized outreach instructors
- Recommendations and solutions to reduce potential arc flash hazards

Power Quality Studies

Square D offers onsite power quality engineering studies and solutions to eliminate process disruptions, power system shutdowns, and equipment damage due to electrical power system disturbances. A power quality study is used to...

- Determine compliance with the IEEE 519-Recommended Practices and Requirements for Harmonic Control in Electrical Power Systems
- Identify most cost-effective solution to power quality problems
- Solve process disruptions due to power disturbances
- Reduce economic effects of poor power quality
- Identify disturbances originating on electric utility system and improvements to reduce the number and severity

Power System Assessment

Square D offers engineering services to meet a variety of power system needs ...

- Basic codes and standards compliance
- Protective coordination assessment
- Maintenance program review
- Recommendations for power system optimization
- Power quality troubleshooting and analysis
- Power factor and harmonics analysis
- Electrical safety hazards
- Short-circuit withstand overview
- Single-line documentation of power system
- Power monitoring recommendations
- Loading measurements

Power System Improvement Projects

Square D offers engineering services for ...

- New equipment installation
- Existing equipment modification
- Ground Fault Schemes for multiple source distribution systems
- High Resistance Grounding (HRG) Conversion
- Automatic Transfer Control Schemes & Generator Operations

Square D professional engineers - safety trained and equipped - will listen to your concerns and goals, define the problem or enhancement, and engineer the solution that best satisfies your needs.

For additional information on power system engineering services and pricing, contact your nearest Square D/Schneider Electric office.

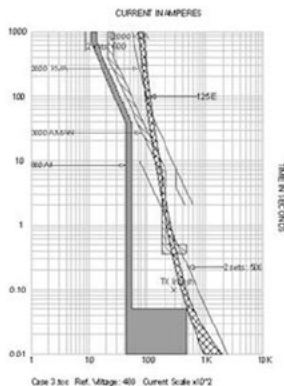

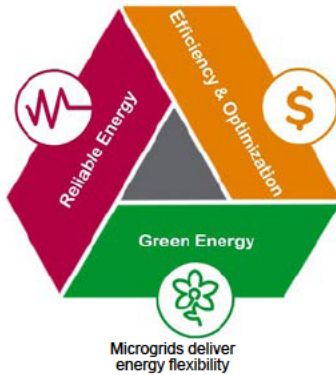

Advanced Microgrid Solutions and Distributed Energy Resource Management

With our custom solutions and proven expertise, we deliver advanced microgrids that offer the advantages of grid independence – without forfeiting the benefits of being part of the central grid. Our flexible microgrid architecture features a scalable set of grid components designed to efficiently manage your entire energy infrastructure, including distributed generation, energy storage, and load demand, while giving you the ability to easily adapt the system to your changing needs. **Learn more at www.microgrids.schneider-electric.us.**

Industrial Energy Efficiency

Schneider Electric Certified Energy Managers (CEM's) work on-site with knowledgeable plant personnel to develop a long-term, comprehensive, "Energy Action Plan", that serves as the blueprint for energy savings. Unlike performance contracts or one-time energy audits, the Total Energy ControlSM program offers a strategic partnership for energy-intensive industrials who want to improve energy efficiency.

- Total Energy Control – Comprehensive integration of all three areas affecting energy efficiency
 - Procurement (electricity and gas)
 - Demand management
 - Optimization of process and plant utilities
- Program deliverables:
 - Long-term Energy Action Plan
 - Energy efficiency projects
 - Ongoing accountability for results

Engineered Solutions

Schneider Electric provides an engineered solution approach to your specific power system applications. Our total solutions for power monitoring and power system controls allow greater safety, reliability, and energy efficiency of your power systems. As a long standing industry leader in Power Monitoring and Control Systems, we understand your power system requirements and needs.

All of our Engineered Solutions are tailored to your specific system requirements. Schneider Electric is your total Solution provider.

Power Monitoring Applications

Increased Reliability and Energy Efficiency are key results produced from our Power Monitoring Applications. Schneider Electric power monitoring applications provide detailed reporting, testing and analysis capabilities for your systems and related components.

- **EPSS Emergency Power Supply Systems**– The PowerLogic EPSS Test Report provides information regarding the health and status of the emergency power supply system, including automatic transfer switches and generators.
- **SER Sequence of Events Recording**– The PowerLogic Sequence of Events Recorder (SER) Module is a root-cause analysis tool for rapid response for problem resolution that is ideal for pinpointing the cause of a service disruption in very large complex power systems.
- **WAGES Water, Air Gas, Electric, Steam**– PowerLogic energy and power management systems can provide instantaneous readings, alarm notifications, and graphical diagrams for monitoring electrical and piped utilities (Water, Air, Gas, Electric, Steam).
- **ENM Event Notification Module**– The PowerLogic Event Notification Module allows automatic paging to alphanumeric pagers, cell phones and PCs.

Power System Control Applications

Automated solutions for increased Reliability and Energy Efficiency: Schneider Electric engineers provide Power System Control Applications with automated solutions for addressing your system reliability and efficiency control needs. Our offer covers Automatic Throwover Schemes, Load Shedding/Peak Shaving, and Load Preservation and Microgrids.

- **Automatic Throwover Systems** – Automatic selection of available utility or generator sources to maintain service continuity to connected loads.
- **Load Shedding/Peak Shaving** – Control peak demand levels or ensure service continuity to critical load or operate breakers in accordance with user specified sequences and time delays such as bringing large motors online across several billing kw demand periods to avoid demand penalties.
- **Load Preservation** – Fast acting sophisticated control systems designed to stabilize critical power systems to the greatest extent possible by monitoring frequency and power sources from utility plus generator capacity versus total circuit load.

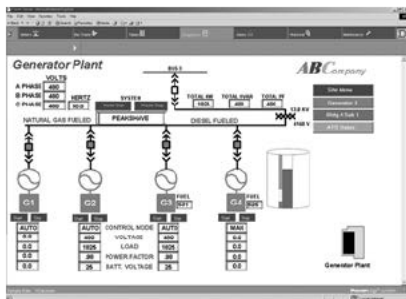

PowerLogic Engineers provide graphic solutions for realtime monitoring of power systems.

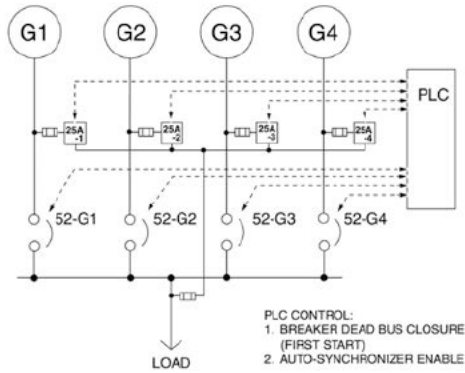

PowerLogic Engineers design power control systems that meet your operational requirements

System Integration

System Design and Engineering

Our Square D Engineering Services solution specialists can work with you to design or upgrade your existing system to best achieve your energy and power management objectives and informational needs. With expertise in electrical systems, communications, and automatic control systems, we can integrate, install, and commission your system for optimal performance.

- System Design and Bill of Material Recommendations
- Power Monitoring and Control
- WAGES (Water, Air, Gas, Electric, Steam)
- Enterprise web-based monitoring
- Specification development, drawings, documentation
- Enclosure panel design and build
- Metering Connection Verification/Testing
- Power distribution automation
- On-Site Installation Assistance, Component Configuration & Startup
- Turn-key project management
- Third Party Device and communication interfaces
- Configured Workstations, User Software Interfaces
- Interactive Graphic Design to mimic facility layout, one-lines, equipment status
- Custom Software, Reports & Applications – Billing and Event Notification



PowerLogic Engineers specialize in the design and setup of Emergency Power Supply Systems (EPSS).

For additional information, contact your nearest Square D / Schneider Electric office.

Factory Assembled Equipment

Square D™ PowerLogic™ Factory Assembled Equipment offers a wide range of designs for metering, communications, and control applications to simplify retrofit installations. Our equipment is designed to order as a free-standing or wallmounted system. With PowerLogic™ Factory Assembled Equipment, you'll receive professionally crafted, factory tested, pre-wired equipment that will greatly improve the speed of your system startup. All backed by the Square D™ quality standard of excellence.

- Assemblies include meters & devices wired to terminal blocks, disconnects, and shorting blocks or test switches
- Tailored to any system voltage :
 - 208/120 V, 480/277 V & 600/347 V Wye
 - 240 V, 480 V & 600 V Delta
 - Utilization of PT's required for higher voltage levels
- Wall mountable and easy to install using concealed holes in the back of the enclosure.
- Complete with necessary documentation and mounting hardware for quick and easy installation
- Carbon steel construction, with industry standard ANSI 61 gray powder coat finish
- Equipped with concealed hinged door, and universal pad-lockable latch.
- Custom engraved nameplates available for all units.

Table 4.37: Industrial Enclosure Types 12 & 4, UL & CUL 508A Listed

Available Meter Types	Digital Inputs	Digital Outputs	Analog Inputs	Analog Outputs
ION6200	N/A	Up to 2/ Meter	N/A	N/A
PM5563RD	Up to 4 / Meter	Up to 2 / Meter	N/A	N/A
PM8244	Up to 15 / Meter	Up to 5 / Meter	Up to 4 / Meter	Up to 2 / Meter
CM4000T	Up to 8 / Meter	Up to 7 / Meter	Up to 1 / Meter	Up to 1 / Meter
ION 7550 & 7560	Up to 16 / Meter	Up to 7 / Meter	Up to 4 / Meter	Up to 4 / Meter

- Supports Single or Multiple Voltage Sources for Indoor (Types 1 and 12) & Outdoor (Type 4) applications
- Available with 1–4 meters per panel. Serial & Ethernet Communications are options for all units
- EGX & ION RTU Communication Enclosures with 1–4 devices per panel also available





Light Industrial Enclosure Type 1, UL & CUL 508A Listed

- Available for the following meter types: PM8244, PM5563RD, and ION6200
- Supports Single Voltage Source only for Indoor (Type 1) applications.
- Available with 1–12 meters per panel. Serial Communications are standard for all units.
- No Digital or Analog I/O is available for this option.

Service Entrance/Utility Socket Enclosure Type 3R, UL & CUL 508A Listed

- Available for ION8600 only, with up to 3 Digital Inputs and 4 Digital Outputs and E5600 2 Digital Inputs and 2 Digital Outputs.
- Supports Single Voltage Source only for Indoor & Outdoor (Type 3R) applications.
- Units are Ring Type with removable cover.
- Available with 1 meter per panel. Serial & Ethernet Communications options available.
- Supports Form 9S, 35S, 36S, 39S and 76S configurations for ION8600 and forms 9S and 36S for E5600.
- Options available for remote mounted CTs
- Options available for integrated, bar type CTs
- Optional Test Switch.

Additional engineered to order products are available for a wide variety of design solutions.

- Switchgear Transfer Control Panels
- Generator Control Panels
- Load Shed Control Panels
- Sequence of Events Recording (SER) Panels
- Control System Mimic Panels
- Lighting Control Interface Panels
- Programmable Logic Controller (PLC) Control Panels (Hot Standby, Relay Control, Data Concentration etc. ...)
- Emergency Power Supply Systems (EPSS) Control Panels
- Water, Air, Gas, Electrical, and Steam (WAGES) Monitoring Panels
- Input Status Monitoring & Alarming Panels
- Remote Annunciator Control Panels
- Remote Operator Control Panels
- Serial, Ethernet, and Cellular Wireless Systems
- Server Rack and Network Equipment (Servers, Switches, UPS's) for Energy Management Systems.
- Industrialized PC's, Touch Screens (Magelis), and Human Machine Interfaces (HMI's) with Custom System Graphics.
- Designed to fit any environment – Indoor (Type 1 & 12) & Outdoor (Type 3R & 4) applications

For additional information and pricing please contact your local PowerLogic sales specialist or PowerLogic Inside Sales Support at Equipment pricing and literature available for download on our website at www.powerlogic.com/products/enclosures.

To better serve you please have the following information on hand when calling.

- Enclosure type (Indoor or Outdoor) and Environment details (Corrosive or Non-Corrosive)
- Power System Voltage Level and Type (Direct Current (DC) or Alternating Current (AC))
- Digital & Analog Input and Output requirements
- Device Type and Quantity per enclosure
- Ethernet and Serial Communication Requirements
- For Drawout Retrofits, need existing cradle type (i.e. GE, Westinghouse, etc.)

4
POWER MONITORING AND CONTROL

PowerLogic High Density Metering

High Density Metering (HDM) is engineered to answer the metering and billing needs of multi-tenant properties:

Features and Benefits

- HDM comes standard with PowerLogic PM5000 series.
- Lockable, 16 gauge NEMA Type 1 enclosure provides tamper-resistant security.
- NEMA Type 3R also available. Please consult factory.
- Mounting channel and surface-mount flanges simplify installation.
- Factory installed cover plates are included to cover empty meter spaces.
- Factory installed wiring harness simplifies installation of additional meters and provides future system expansion.
- Each High Density Metering cabinet is provided with RS485 Modbus® or Modbus Ethernet TCP communications. For wireless communications, please consult factory.
- Supports 120/208V & 277/480V WYE, and 240V & 480V Delta System Types, 1Ph or 3Ph
- CTs required. Must select separately.

High Density Meter System Includes:

- Enclosure
- Power Meters, installed
- Installation bulletin for Enclosure
- Wall hanging bracket
- Installation bulletin for Meters



High Density Metering factory assembled enclosure for multi-tenant properties

Table 4.38: High Density Metering Cabinet

Category	Meter	Enclosure Size	Number of Meters [8]	Enclosure Rating	Description
HDM	PM5110	1, 4 or 8	1-8	Type 1 or Type 3R	High Density Meter Enclosure with PM5110 meters; Modbus RTU serial communications; Ideal for single or three phase indoor commercial building applications
HDM	PM5330	1, 4 or 8	1-8	Type 1 or Type 3R	High Density Meter Enclosure with PM5330 meters; Modbus RTU serial communications; Ideal for single or three phase indoor commercial building applications
HDM	PM5340	1	1	Type 1 or Type 3R	High Density Meter Enclosure with PM5340 meters; Modbus TCP Ethernet communications; Ideal for single or three phase indoor commercial building applications
HDM	PM5560	1, 4 or 8	1-8	Type 1 or Type 3R	High Density Meter Enclosure with PM5560 meters; Dual wiring for both Modbus RTU serial and Modbus TCP Ethernet communications; Ideal for single or three phase indoor commercial building applications

Table 4.39: Accessories

Description	Catalog No.
50 Amp HDM Solid Core Current Transformer, 1.13" window size	HDMCT050S1
100 Amp HDM Solid Core Current Transformer, 1.13" window size	HDMCT100S1
125 Amp HDM Solid Core Current Transformer, 1.13" window size	HDMCT125S1
150 Amp HDM Solid Core Current Transformer, 1.13" window size	HDMCT150S1
200 Amp HDM Solid Core Current Transformer, 1.13" window size	HDMCT200S1
250 Amp HDM Solid Core Current Transformer, 1.13" window size	HDMCT250S1
400 Amp HDM Solid Core Current Transformer, 1.13" window size	HDMCT400S1

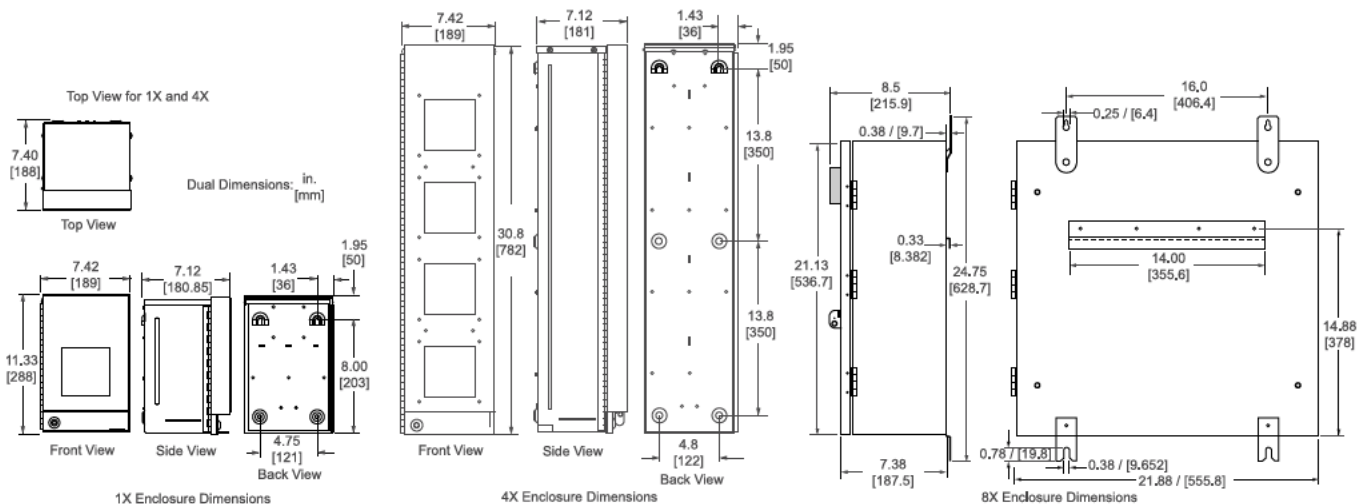

[8] Meters Ordering Notes: Please indicate the number of meters to be pre-installed when placing your order. You may order any number of meters in the enclosure between one and the maximum number of meters each cabinet will hold.

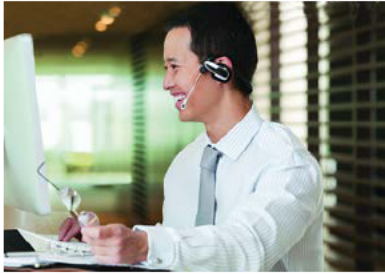

Technical Engineering Support Services

No power management system is complete without it. Technical support should go beyond basic troubleshooting. Continued optimization and maintenance extends the life of your system and ensures it's working efficiently and effectively. Our number one priority is to help you protect your investment and get the most out of it.

- Proactive diagnostics and maintenance
- Access to our self-help web portal and knowledge base
- Email, telephone, and remote VPN troubleshooting assistance
- On-demand and in-person training

A variety of service levels available based on your needs and budget, plus options add-ons such as onsite maintenance or 24x7 support, allows you to build the support that's right for your system.

Premium +

Our most comprehensive service level is ideal for large organizations with mission critical systems, multiple locations and/or in-house energy management expertise.

Premium

Great for the experienced manager with complex power management systems and/or multiple locations, you can choose Premium support and partner with a dedicated engineer to help you drive improved system performance.

Priority

Sign up for Priority support and benefit from the expertise of our senior technical engineers. They can remotely connect to your system and resolve issues while you observe or work on other tasks.

Standard

We stand behind our products. If you have the time and knowledge to do-it-yourself, then we're happy to assist you with troubleshooting or answer your questions at no extra cost. Priority Support: Excellent Service, Free Software Upgrades, Training Discounts & More!

Energy Performance Services

Unleash Your System's True Potential with the Power of Partnership

Energy Performance Services helps you improve and sustain energy performance, reduce costs, and support compliance efforts. From facility insight to optimization solutions, let us customize an energy management program that's right for you. Contact your representative and ask them about power quality analysis or an energy health check.

Solutions to fit your needs:

- Facility Insight Solutions—These core energy health checks designed to evaluate your existing systems
- Optimization Solutions—Let our team of experts monitor or fine-tune your systems to maximize energy savings, efficiency and power quality.

Choose from remote or onsite solutions to ensure sustained results year over year. Various funding options available. Visit [www.schneider-electric.com/energy-performance](#) or contact us at [1-800-475-6634](#)

Power Management University (PMU)

Attending a PMU sponsored course will enable attendees to better utilize their Schneider-Electric power monitoring solution thus enabling them to realize energy savings as quick as possible. PMU offers a variety of options with instructor led options being 80% hands-on, with each student having their own lab workstation. Below is a list of the different training options offered by PMU.

Course	Course No.	Length
Factory Courses Software Solutions		
Power Monitoring Fundamentals Bundle (includes 12-mo. On-Demand Campus access)	3000PMUFUNDSPMCR	4 Days
Power Monitoring Fundamentals (without 12-mo. On-demand Campus access)	3000PMUFUNDSPM	4 Days
Power Monitoring Designer	3000PMUPROG	4 Days
Power Monitoring Administrator	3000PMUADMINSPM	4 Days
Other Software Courses		
Hardware Installation and Troubleshooting	3000PLUC100	4 Days
PowerSCADA Expert Administrator	3000PMUPLSADMIN	4 Days
Online Training Solutions		
On-Demand Campus (one-year subscription—online access)	3000PMUDEMAMND12	12 months
SMSTrainer (one-year subscription—online access)	3000PMUSMSTRAINER	12 months
EEMTrainer (one-year subscription—online access)	3000PMUEEMTRAINER	12 months
webED, custom webinar training for up to five people (call or email for more information)	3000PLUCWBCST	3-4 hours



The Sepam Range

Sepam protection relays are time-tested, high-performance devices that ensure dependability. This range of products was designed with a simple idea in mind: All users should be able to find a solution corresponding exactly to their needs with the right balance between performance, simplicity and cost. With Series 10, 20, 40 and 80, the Sepam range does just this. This family of relays offers a solution for every application need, specifically targeting industrial installations. These multi-functional protection devices allow an easy and hassle-free startup with simple-to-use programming software. Sepam relays also comply with the latest communication protocols on the market, including IEC61850, DNP3 and Modbus. In addition, all relays within this range come with a standard 10 year warranty and conformal coating for protection against harsh environments.

Features and Benefits

- Compact devices with clearly defined connection terminals allowing for easy installation
- User-friendly software with built-in manuals for every relay and support for offline programming
- Application-specific design ensuring appropriate protection for any given application
- Low power CT options for the use of relays on new installations where the load is low
- Field-upgradable technology allows user to stay up-to-date on the latest hardware and software

Sepam Series 10

The Sepam Series 10 relays are suitable for basic protection applications involving current metering.

Applications covered:

- Substation
- Transformer



Sepam Series 10

Sepam Series 20

The Series 20 consists of high-performing solutions suited for standard applications requiring current or voltage metering.

Applications covered:

- Substation
- Transformer
- Motor
- Busbar



Sepam Series 20 and 40

Sepam Series 40

The Series 40 family of protection relays are designed for demanding applications requiring current, voltage and/or frequency metering.

Applications covered:

- Substation
- Transformer
- Motor
- Generator

Sepam Series 80

The Series 80 relays are for custom applications requiring enhanced protection of electrical distribution networks.

Applications covered:

- Substation
- Transformer
- Motor
- Generator
- Busbar
- Capacitor



Sepam Series 80

Protection Configurations

Four relay series with increasing protection capabilities for six types of applications to provide all possible protection configurations

Table 4.40: Protection Configurations

Protection Functions	Series 10	Series 20	Series 40	Series 80
Protection Functions	49RMS, 50/51, 50G/51G, 50N/51N, 68, 86	26/63, 27/27S, 27D, 27R, 30, 37, 38/49T, 46, 48, 49RMS, 50/51, 50BF, 50G/51G, 50N/51N, 51LR, 59, 59N, 66, 68, 79, 81H, 81L, 81R, 86, 94/69, CPLU 50/51, CPLU 50N/51N	25, 26/63, 27/27S, 27D, 27R, 30, 32R, 32Q/40, 37, 38/49T, 46, 47, 48, 49RMS, 50/51, 50BF, 50G/51G, 50N/51N, 50V/51V, 51LR, 59, 59N, 60/60FL, 66, 67, 67N/67NC, 68, 79, 81H, 81L, 81R, 86, 94/69, 21FL, 46BC, CPLU 50/51, CPLU 50N/51N	12, 14, 21B, 24, 25, 26/63, 27/27S, 27D, 27R, 30, 32P, 32Q/40, 37, 37P, 38/49T, 40, 46, 47, 48, 49RMS, 50/27, 50/51, 50BF, 50G/51G, 50N/51N, 50V/51V, 51C, 51LR, 59, 59N, 60/60FL, 64G, 64REF, a 66, 67, 67N/67NC, 68, 74, 78PS, 79, 81H, 81L, 81R, 86, 87M, 87T, 94/96
Characteristics				
Logic input/outputs	Inputs 0-4 Outputs 3-7	Inputs 0-10 Outputs 4-8	Inputs 0-10 Outputs 4-8	Inputs 0-42 Outputs 5-23
Temperature sensors	0	0-8	0-16	0-16
Channels	Current 3I + Io —	Current 3I + Io Voltage 3 V + Vo	Current 3I + Io Voltage 3 V + Vo	Current 2x 3I + 2x Io Voltage 2x 3 V + Vo
Communication Ports	0-1 ModBus, IEC 103	1-2 ModBus, IEC 103, DNP3, IEC 61850	1-2 ModBus, IEC 103, DNP3, IEC 61850	2-4 ModBus, IEC 103, DNP3, IEC 61850
Control	Matrix [2]	Matrix [2]	Matrix [2] Logic equation editor	Matrix [2] Logic equation editor Logipam [3]
Other	—	—	— Backup 48 hours (capacitor)	Front memory cartridge with settings Backup lithium battery [4]

Table 4.41: ANSI Codes

Code	Definition	Code	Definition
12	Overspeed (2 set points)	50N/51N	Ground fault
14	Underspeed (2 set points)	50V/51V	Voltage restrained overcurrent
21B	Underimpedance	51C	Capacitor bank unbalance
21FL	Fault Locator	51LR	Locked rotor
24	Overfluxing (V/Hz)	59	Overvoltage (L-L or L-N)
25	Synch-check	59	Overvoltage (L-L)
26/63	Thermostat / Buchholz	59N	Neutral voltage displacement
27/27S	Undervoltage (L-L/L-N)	60/60FL	CT/VT supervision
27D	Positive-sequence undervoltage	64G	100% stator earth fault
27R	Remanent undervoltage	64REF	Restricted earth fault
30	Annunciation	66	Starts per hour
32P	Directional real overpower	67	Directional phase overcurrent
32Q/40	Directional reactive overpower	67N/67NC	Directional ground fault
37	Phase undercurrent	68	Logic discrimination / zone selective interlocking
37P	Directional active underpower	74	Circuit connection supervision
38/49T	Temperature mounting	78PS	Pole slip
40	Field loss (underimpedance)	79	Recloser (4 cycles)
46	Unbalance/negative sequence	81H	Overfrequency
46BC	Broken conductor detection	81L	Underfrequency
47	Negative sequence overvoltage	81R	Rate of change of frequency (df/dt)
48	Excessive starting time	86	Latching / acknowledgement
49RMS	Thermal overload	87M	Machine differential
50/27	Inadvertent energization	87T	Two-winding transformer differential
50/51	Phase overcurrent	94/69	Circuit breaker / contactor control
50BF	Breaker failure	CLPU 50/51	Cold load pick-up with phase overcurrent protection
50G/51G	Ground sensitive	CLPU 50N/51N	Cold load pick-up with earth fault protection

[1] LPCT: low-power current transducer complying with standard EC 60044-8.
 [2] Control matrix for simple assignment of information from the protection, control and monitoring functions.
 [3] Logipam ladder language (PC programming environment) to make full use of Sepam Series 80 functions.
 [4] Standard lithium battery 1/2 AA format 3,6 V front face exchangeable.



VAMP V321 Arc Flash Mitigation System

New!

VAMP V321 Arc Flash Mitigation System

- VAMP V321 is the fastest and most advanced arc flash mitigation system on the market.
- As a fast-acting arc flash mitigation system, VAMP V321 reduces the level of incident energy within a switchgear, thereby reducing equipment damage.
- VAMP V321 is a modular system consisting of a central unit, input/output (I/O) units and arc flash sensors. Its modular design gives it the flexibility to expand and adapt to various applications in an electrical distribution system.

System Features

- Operates on light and/or overcurrent conditions
- Operating time of 2 ms or less
- Supports up to 16 I/O units and 170 arc flash sensors
- Four programmable arc protection zones per central unit
- Fully configurable using VAMPSet software
- Mimic bus display
- Supports nearly every communication protocol on the market
- Phase current measuring
- Ground fault current measuring
- Circuit breaker fail protection (50BF)

New!

VAMP V321 I/O Units

The I/O units are used to connect sensors to the central unit in the VAMP V321 system. These units are classified as either light sensor or current I/O units.



- VAM 12L, VAM 12LD: Light-sensing point sensor I/O units with connections for 10 arc sensors and 3 trip contacts
- VAM 10L, VAM 10LD: Light-sensing point sensor I/O units with connections for 10 arc sensors and 1 trip contact
- VAM 3L, VAM 3LX: Light-sensing fiber arc sensor I/O units with connections for 3 fiber loops and 1 trip contact
- VAM 4C, VAM 4CD: Dedicated I/O units used to measure current from alternative locations

All VAMP V321 I/O units provide active indication when appropriately placed inside the switchgear enclosure. They are connected to each other using intra-unit cabling supplied by Schneider Electric.

VAMP V321 Sensors and Accessories

- **Point sensor VA1EH-x (pipe)** Installed typically in the tube or next to the compartment window.
- **Point sensor VA1DA-x (surface)** Compartment wall or mounting plate installation.
- **Arc SLM-x** Used when a large number of compartments are to be monitored.
- **VX001 Modular Cable** Intra-unit cabling that is used to connect the I/O units to the central unit.



VA1EH-x



VA1DA-x



Arc SLM-x



VX001

VAMP V321 is currently available in solution-based projects. Please contact a Schneider Electric representative for more information.

Reactive Power Compensation and Harmonic Mitigation Solutions

How can reactive power compensation and harmonic mitigation solutions be part of your energy efficiency programs?

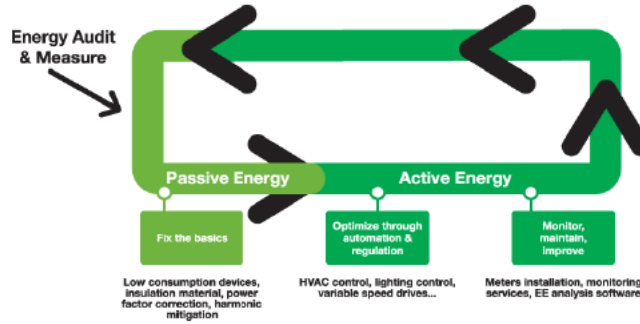

Power factor is a measure of how efficiently you are using electricity. In an electric power system, a load with low power factor draws more current than a load with a high power factor for the same amount of real power transferred. Utility customers with a low power factor could realize an increase or penalty in their electric bill. Over time, these penalties may reach into thousands of dollars, depending upon the utility's rate structure.

Harmonics may disrupt normal operation of other devices and increase operating costs. Symptoms of problematic harmonic levels include overheating of transformers, motors and cables, thermal tripping of protective devices, logic faults of digital devices and drives.

Harmonics can cause vibrations and noise in electrical machines (motors, transformers, reactors).

The life span of many devices can be reduced by elevated operating temperature.

Schneider Electric provides different solutions to meet different application requirements.

Table 4.42: Descriptions, Applications, and Features

Product Description	LV	MV	Application	Product Features
ReactiveVar Fixed Power Factor Capacitors	X	X	Power Factor correction	Suited for applications where the load does not change or where the capacitor is switched with the load, such as on the load side of a motor contactor.
ReactiveVar Standard Automatic Power Factor Capacitor Banks (AV5000/MV5000)	X	X	Power Factor correction	Suited for centralized power factor correction in applications where plant loading is constantly changing, resulting in the need for varying amounts of reactive power. Designed for electrical networks with little or no harmonic content.
ReactiveVar Anti-Resonant Automatic Power Factor Capacitor Banks (AV6000/MV6000)	X	X	Power Factor Correction and Harmonics Filtering	Suited for centralized power factor correction in applications containing harmonic energies that would otherwise damage standard fixed or automatic capacitor banks.
ReactiveVar Harmonic Filtering Automatic Power Factor Capacitor Banks (AV7000/MV7000)	X	X	Power Factor Correction and Harmonics Filtering	Provides power factor correction as well as harmonic filtering with specific harmonic order (5th) in industrial networks.
ReactiveVar Transient Free Reactive Compensation Systems (AT6000/AT7000)	X		Power Factor Correction and Harmonics Filtering	Enhanced technology utilizing solid state switching elements that replace standard electromechanical contactors. Provides quicker response to load fluctuations with transient free capacitor switching.
AccuSine™ (PCS) Active Harmonic Filter	X	X [1]	Active Harmonic Filtering	Monitors a distorted electrical signal and determines the frequency and magnitude of harmonics in the signal. Cancels the harmonic content with the dynamic injection of opposing phase current in the distribution system or individual load.
ReactiveVar Hybrid VAR Compensator (HVC)	X	X [1]	Reactive Power Compensation (Real-time)	Provides real-time reactive power compensation, and voltage support in networks with highly cyclical load profiles.

[1] With transformer.

Low Voltage Fixed Capacitors

ReactiVar low voltage fixed capacitors are ideally suited for power factor correction applications where the load does not change or where the capacitor is switched with the load, such as on the load side of a motor starter. ReactiVar fixed capacitors are best suited for applications where there are no harmonic currents or voltages present.

Application Note: Capacitors are low impedance path for the harmonic currents produced by variable frequency drives, motor soft starters, welders, computers, PLCs, robotics and other electronic equipment. These harmonic currents can cause the capacitor to overheat, and shorten its life. Furthermore, the resonant circuit formed by shunt capacitors coupled with system inductances (motors and transformers) can amplify harmonic currents and voltages in the electrical network. This amplification can cause nuisance fuse operation and/or damage to electrical equipment including capacitors and other electronic devices. If power factor correction is required in the network where harmonic is present, please contact your nearest Square D/Schneider Electric sales office for assistance.

Features

- Heavy edge, slope metallizations and wave-cut profile to ensure high inrush current capabilities.
- Special resistivity and profile metallization for better self-healing and enhanced life (up to 130,000 hours).
- Unique safety feature which disconnects the capacitors at the end of their useful life electrically.
- Less than 0.5w/kVAR losses, including discharge resistors.
- Constructed with a dry type metallized polypropylene capacitor element with no liquid dielectrics.
- Can be easily mounted inside panels or in a stand alone configuration.

Table 4.43: Unfused 208 V 3 phase/ 60Hz unit [2]

kVAR rating	Regular duty Indoor NEMA 1 unit	Rated Current (A)	Recommended copper wire size[3]	Recommended circuit protection device rating[4]	
				Fuse	Circuit breaker
@ 208 V	Catalog Number	@ 208 V	AWG	Fuse	Circuit breaker
2	PFCD1002	6.3	14	15	15
5	PFCD1005	13.6	10	30	20
6	PFCD1006	17.7	10	40	25
7.5	PFCD1007	20.9	8	45	30
10	PFCD1010	27.1	8	60	40
13	PFCD1013	35.4	6	75	50
15	PFCD1015	41.7	4	90	60
17	PFCD1017	48	4	100	70
21	PFCD1021	59.4	3	125	90
25	PFCD1025	68.8	2	150	100
27	PFCD1027	75.1	2	150	110
30	PFCD1030	83.4	1	175	125
34	PFCD1033	93.8	1/0	200	150
37.5	PFCD1037	104.3	2/0	225	150
41	PFCD1040	114.7	2/0	250	175
45	PFCD1045	125.1	3/0	250	175
49	PFCD1048	135.5	4/0	300	200
53	PFCD1053	147	4/0	300	225
60	PFCD1060	168.9	300 kcmil	350	250
70	PFCD1070	198.1	350 kcmil	450	300
80	PFCD1080	222	500 kcmil	450	350

Table 4.44: Unfused 240 V 3 phase/ 60Hz unit [2]

kVAR rating	Regular duty Indoor NEMA 1 unit	Rated Current (A)	Recommended copper wire size[3]	Recommended circuit protection device rating[4]	
				Fuse	Circuit breaker
@ 240 V	Catalog Number	@ 240 V	AWG	Fuse	Circuit breaker
3	PFCD2003	7.2	14	15	15
6	PFCD2006	15.6	10	35	25
8	PFCD2008	20.5	8	45	30
10	PFCD2010	24.1	8	50	35
13	PFCD2013	31.3	6	70	45
15	PFCD2015	36.1	6	75	50
17.5	PFCD2017	40.9	6	90	60
20	PFCD2020	48.1	4	100	70
22.5	PFCD2023	55.3	3	125	80
25	PFCD2025	61.4	3	125	90
27.5	PFCD2028	68.6	2	150	100
30	PFCD2030	72.2	2	150	100
32.5	PFCD2033	79.4	1	175	110
37.5	PFCD2036	86.6	1	175	125
40	PFCD2040	96.2	1/0	200	150
45	PFCD2045	108.3	2/0	225	150
50	PFCD2050	120.3	2/0	250	175
60	PFCD2060	144.4	4/0	300	200
70	PFCD2070	169.6	300 kcmil	350	250
80	PFCD2080	194.9	350 kcmil	400	300
90	PFCD2090	218.9	400 kcmil	450	300
100	PFCD2100	239.4	500 kcmil	500	350

Table 4.45: Unfused 480V 3 phase/ 60Hz unit [2]

kVAR rating	Regular duty Indoor NEMA 1 unit	Rated Current (A)	Recommended copper wire size[3]	Recommended circuit protection device rating[4]	
				Fuse	Circuit breaker
@ 480 V	Catalog Number	@ 480 V	AWG	Fuse	Circuit breaker
6	PFCD4006	7.2	14	15	15
8	PFCD4008	10.2	12	20	15
10	PFCD4010	12	12	25	20
12.5	PFCD4012	15	10	30	25
15	PFCD4015	18	10	40	30
17	PFCD4017	19.8	8	40	30
20	PFCD4020	24	8	50	35
25	PFCD4025	30	6	60	45
27.5	PFCD4027	33	6	70	50
30	PFCD4030	36	6	75	50
33	PFCD4033	39.6	6	80	60
35	PFCD4035	42	4	90	60
40	PFCD4040	48	4	100	70
45	PFCD4045	54	4	110	75
50	PFCD4050	60	3	125	90
60	PFCD4060	72	2	150	100
65	PFCD4065	78	1	175	110
70	PFCD4070	84	1	175	125
75	PFCD4075	90	1/0	200	125
80	PFCD4080	96	1/0	200	150
90	PFCD4090	108	2/0	225	150
100	PFCD4100	120	2/0	250	175
125	PFCD4125	150	250	300	225
150	PFCD4150	180	300	400	250
175	PFCD4175	210	400	450	300
200	PFCD4200	240	500	500	350

Table 4.46: Unfused 600V 3 phase/ 60Hz unit [2]

kVAR rating	Regular duty Indoor NEMA 1 unit	Rated Current (A)	Recommended copper wire size[3]	Recommended circuit protection device rating[4]	
				Fuse	Circuit Breaker
600 V	Catalog Number	@ 600 V	AWG	Fuse	Circuit Breaker
10	PFCD6010	9.6	12	20	15
15	PFCD6015	14.4	10	30	20
20	PFCD6020	19.2	10	40	30
23	PFCD6022	22.1	8	50	35
25	PFCD6025	24	8	50	35
27	PFCD6027	26	8	50	40
30	PFCD6030	28.8	8	60	45
35	PFCD6035	33.6	6	70	50
40	PFCD6040	38.4	6	80	60
45	PFCD6045	43.2	4	90	60
50	PFCD6050	48	4	100	70
60	PFCD6060	57.6	3	125	80
70	PFCD6070	67.2	3	150	100
75	PFCD6075	72	2	150	100
80	PFCD6080	76.8	1	150	110
90	PFCD6090	86.4	1	175	125
100	PFCD6100	96	1/0	200	150
125	PFCD6125	120	3/0	250	175
150	PFCD6150	144	4/0	300	200
175	PFCD6175	168	300 kcmil	350	250

[2] For fused unit, add suffix "F" to the existing part number. Consult Schneider Electric sales office for pricing.

[3] Conductor should be copper and rated 90 °C min. Refer to local electrical codes for proper wire size

[4] Consult local electrical codes for proper sizing of molded case circuit breaker frame or disconnect switch rating



The AV5000 is suitable for use where harmonic generating loads are less than 15% of the total connected load (AV5000 shown here).

Low Voltage Standard Automatic Capacitor Banks

The AV5000 standard automatic power factor correction banks are designed for centralized power factor correction to supply varying amounts of reactive power required to compensate for changing load conditions. The AV5000 banks are ideally suited for facility electrical distribution systems with TDD (total harmonic current distortion) $< = 5\%$ and THD(V) (total harmonic voltage distortion) $< = 5\%$. An advanced power factor controller measures plant power factor via a single remote CT. Plus, it switches capacitor modules in and out of service to maintain a user selected target power factor.

Main Features:

- Modular construction; free standing QED switchboard enclosures (30wx36dx90h) and allow for easy future expansion
- Rugged design — units are constructed with removable steel panels over heavy gauge steel frame
- Standard offering available up to 400 kVAR at 208 Vac, 1000 kVAR at 480 or 600 Vac
- Main lugs or main breaker section at your choice
- Dry capacitor element design eliminates risk of fluid leakage, environmental hazard and drip pans
- Capacitor rated contactors are designed specifically for the switching of capacitive currents and feature a patented capacitor precharge circuit that exceeds air-core reactor transient dampening
- Different power factor controller options provide a choice in functionality and control sophistication
- Backlit display on controller displays actual power factor (PF), alarms, number of steps energized and much more
- Available in NEMA 1 and NEMA 3R enclosures

Low Voltage Anti-Resonant and Filtering Automatic Capacitor Banks

ReactiVar AV6000 anti-resonant and AV7000 harmonic filtering automatic switched capacitor banks are specifically designed for networks containing harmonic energies which would otherwise damage standard fixed or automatic capacitor banks.

The problem: Harmonics are caused by non-linear loads such as variable frequency drives, motor soft starters, welders, uninterruptable power supplies, robotics, PLCs and other electronic devices. Harmonics are higher-than-60 Hz current and voltage components in the electrical distribution system. Capacitors are a low impedance path for these higher frequency components and thus absorb the harmonic energies. Combinations of capacitors and system inductances (motors and transformers) can form series and parallel tuned circuits which can resonate at certain frequencies. The harmonics caused by non-linear loads can excite a standard capacitor bank into resonance. The resonance can magnify currents and voltages, causing system wide damage and equipment failure. This problem is growing in today's distribution systems.

The Solution: Anti-Resonant Automatic Capacitor Banks The AV6000 anti-resonance capacitor bank's primary function is power factor correction. Iron core reactors are added in series with the capacitor modules. The 3 phase reactors are custom designed and manufactured under tight tolerance specifically for the AV6000. The reactors tune the bank below the first dominant harmonic (usually the 5th, or 300 Hz). Below the tuning point, the system appears capacitive and thus corrects power factor. Above the tuning point, the system appears inductive and thus resonance is minimized. The AV6000 design has the added advantage of removing up to 50% of the 5th harmonic to reduce overall voltage distortion.

Harmonic Filtering Automatic Capacitor Banks Although the AV7000 looks identical to the AV6000, its primary function is harmonic mitigation, with power factor correction being a secondary benefit. The distinction between an AV6000 and an AV7000 is the tuning point. By definition, if the tuning point of the capacitor/reactor combination is within $\pm 10\%$ of the target harmonic it is intended to absorb, it is referred to as a filter. If the tuning point is outside the $\pm 10\%$ limit, it is referred to as an anti-resonant system. Schneider Electric power quality solution experts should be consulted prior to recommending AV7000 to customers.

Main Features:

- Standard offering available up to 480 kVAR at 208 V, 1200 kVAR at 480 or 600 Vac
- Capacitor modules are designed with higher than standard voltage and current ratings to provide long life on systems with high harmonic energies. Reactors are designed to operate at 115 °C rise over a maximum 40 °C ambient temperature.
- In addition to the standard features provided in the AV5000 systems, the reactors in the AV6000 and AV7000 have an embedded thermistor temperature detector. The stage will shut down and annunciate if the reactor is overheated, usually a result of excessive harmonic energies

Application Assistance: Schneider Electric power quality experts can provide engineering assistance for the application of capacitors in harmonic rich environments. Specialists can assess the likelihood of application problems and arrange for more detailed study if required. Solutions can include computer modeling and system simulation. Our application engineers can arrange for systems studies, provide custom engineering proposal, perform installation and commissioning, as required by the application. Please contact Schneider Electric power quality experts or email us at



AV 6000 Capacitor Bank

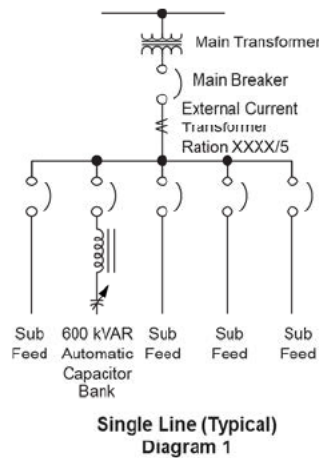

CT Selection

The current transformer is located on a phase A bus or cable at the main service entrance as illustrated in Diagram 1.

CT catalog number: TRAI-***SC ♦♦ where *** is current rate code of bus/cable and ♦♦ is window size code. Codes are listed in table 4.42. e.g. TRAI1000SC07 is a CT for 1000 A bus with 7"x4" window.

Table 4.47: CT Selection Table

Current Rating of Bus/Cable		Window Size	
Amperes	Rating Code ***	7" x 4" Size Code ♦♦	11" x 4" Size Code ♦♦
300	0300	07	11
400	0400	07	11
500	0500	07	11
600	0600	07	11
750	0750	07	11
800	0800	07	11
1000	1000	07	11
1200	1200	07	11
1500	1500	07	11
1600	1600	07	11
2000	2000	07	11
2500	2500	07	11
3000	3000	07	11
3500	3500	07	11
4000	4000	07	11
5000	5000	N/A	11
6000	6000	N/A	11

Low Voltage Transient Free Reactive Compensation Capacitor Banks

Square D™ ReactiVar Transient Free Reactive Compensation (TFRC) anti-resonant (AT/BT6000) systems and filtering system (AT/BT7000) are ideally suited for use on electrical systems where connected equipment is extremely sensitive to variations in the supply voltage.

The problem: Capacitor systems featuring electromechanical contactors could generate voltage transients on the electrical network when they switch capacitor stages on/off, even when current limiting or tuning reactors are employed. Transients can impair the operation of sensitive equipment, including programmable logic controllers, variable speed drives, computers and UPS systems. In sensitive networks such as hospitals, data processing centers, airports and many manufacturing environments, any transient, however slight, may not be acceptable.

The solution: TFRC systems feature an advanced controller to precisely activate electronic switching elements to connect capacitor stages and avoid the creation of transients. Transient free switching also reduces wear on capacitors due to switching and will result in longer life for the overall capacitor system. With a response time of less than ten seconds to load changes, TFRC systems can reduce the kVAR or kVA demand quickly.

Main Features:

- Standard offering up to 1350 kVAR at 480 Vac
- Transient free switching of capacitor steps
- Electronic switching elements yield an unlimited number of switching operations
- Different power factor controller options provide a choice in functionality and control sophistication
- Backlit display on controller displays actual PF, alarms, number of steps energized and much more
- Heavy duty dry capacitor element design provides no risk of fluid leakage, no environmental pollution and no need for drip pans
- The reactors have an embedded thermistor temperature detector. The stage will shut down and annunciate if the reactor is overheated which is usually a result of excessive harmonic energies
- Units are constructed with removable heavy duty steel panels over heavy gauge steel frame.
- Available in NEMA 1 and NEMA 3R enclosures.



AT6000 Transient Free Capacitor Bank

Low Voltage Capacitor Bank General Specifications	
Voltage:	208, 240, 480, 600 Vac standard, other voltages available
Ambient temperature:	-5 °C to 40 °C
Average temperature limit:	<=40 °C within 24 hours, <35 °C over 1 year
Elevation:	<=1800 meter (6000 feet)
Humidity:	0-95% non-condensing
Overvoltage limit:	110% maximum (continuously)
Dielectric withstand test level:	2.15 times rated voltage or 1000 V, whichever is higher for 10s
Overcurrent limit:	135% maximum (continuously)
Incoming:	Top (standard), bottom.
Main lug:	Copper mechanical standard, compression optional
Main breaker (BT):	PowerPact™ with Micrologic™ trip unit. LI standard, LSI available
Enclosure rating:	NEMA 1 standard, N3R available
Color:	ANSI 49 standard, ANSI 61, ANSI 70 optional
Standards:	CSA C22 2 No. 190, UL810

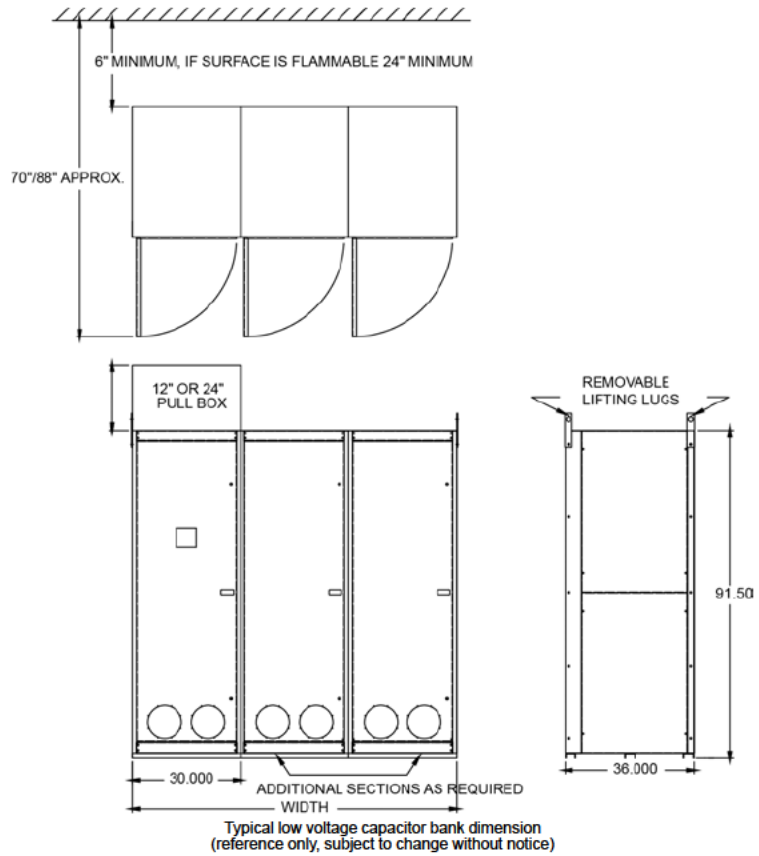

MVC systems are suitable for power factor correction of steady and harmonic-free motor loads.

Medium Voltage Fixed Capacitors

The ReactiVar MVC fixed capacitors are ideally suited for power factor correction in applications where the load does not change or where the capacitor is switched with the load, such as the load side of a motor contactor. ReactiVar capacitor sizes are available up to 300 kVAR as individual units, and up to 900 kVAR in banks.

Main Features:

- Standard rating up to 900 kVAR, 4800 V (for specials, consult factory)
- Extra low dielectric loss (<0.15w/kVAR), including discharge resistors
- Internally mounted discharge resistors
- Internally delta connected capacitor elements
- Built to applicable NEMA, IEEE, and IEC standards
- Available in indoor (Type 1/12) and outdoor (Type 3R) enclosures
- Painted ASA 70 gray

Application Note:

Capacitors are low impedance path for the harmonic currents produced by variable frequency drives, motor soft starters, welders, computers, PLCs, robotics and other electronic equipment. These harmonic currents can cause the capacitor to overheat, and shorten its life. Furthermore, the resonant circuit formed by shunt capacitors coupled with system inductances (motors and transformers) can amplify harmonic currents and voltages in the electrical network. This amplification can cause nuisance fuse operation and/or damage to electrical equipment including capacitors and other electronic devices. If power factor correction is required in the network where harmonic is present, please contact your nearest Square D/Schneider Electric sales office for assistance.



MV5000 systems are suitable for use where harmonic generating loads are less than 15% of the total connected load.
MV6000 systems are suitable for use where harmonic generating loads are less than 50% of the total connected load.
MV7000 systems are suitable for use where harmonic generating loads exceed 50% of the total connected load.
MVHVC High-Speed compensation systems are designed for reactive power compensation of rapidly fluctuating loads.

Medium Voltage Metal Enclosed Capacitor Systems

The medium voltage capacitor systems are ideally suited for centralized power factor correction and/or harmonic filtering in applications. Various equipment topologies are available, from fixed stage to fully automatic—to cover project specific application, load characteristic and installation needs. ReactiVar brand covers metal enclosed systems built in North America (5/15 kV class). Global =S= Brand can be used for expanded voltage range.

Main Features:

- Designed and built per applicable ANSI/NEMA/IEEE and/or IEC standards
- Standard metal enclosures available up to 20 mVAR, up to 34.5 kV, 50/60 Hz
- Steel or Aluminum based enclosure bays
- Externally or internally fused capacitors with excellent life due to high temperature withstand, small temperature rise, chemical stability, overvoltage and overcurrent withstand.
- Current limiting capacitor fuses with blown fuse pop-up indicators
- Inrush current limiting reactors or tuned (anti-resonant or filtered) iron core reactors
- Key interlocking system forces sequential operation of the controls,
- Fully rated three- or four-pole grounding switches
- Schneider Electric NRC12 Power factor controller provides user with friendly interface, superior performance, simplified installation and set-up procedure, and real time monitoring and protection features for the capacitor system.
- Available in Type 1 indoor and 3R outdoor enclosure types

High Voltage Reactive Power Compensation Systems

The high voltage reactive power compensation systems are ideally suited for installation at utility distribution and transmission grids. Various equipment topologies are available to cover project specific utility application, and installation needs. Typically these compensation systems are open style, rack mounted, installed in utility substation areas.

Main Features:

- Custom designed and built per requested applicable standards
- Systems rated up to 230 kV, 50/60 Hz
- Internally fused capacitors with excellent life due to high temperature withstand, small temperature rise, chemical stability, overvoltage and overcurrent withstand.
- Double wye ungrounded configuration with neutral CT protection
- Inrush current limiting or tuned (anti-resonant or filtered) air core, open style reactors

New!

AccuSine PCS+ Active Harmonic Filter (AHF)

AccuSine PCS+ Active Harmonic Filter (AHF) injects harmonic current to cancel harmonic current in the electrical distribution system. This reduced harmonic level results in improved electrical network reliability and reduced operating cost. AccuSine PCS+ is simple to size, install, set up and operate. In addition, AccuSine PCS+ eliminates the complex harmonic compliance limit calculations and removes nuisance harmonics from the electrical network.

The Problem:

Power electronic devices that have rapid and frequent load variations have become abundant today due to their many process control related and energy saving benefits. However, they also bring a few major drawbacks to electrical distribution systems; harmonics and rapid change of reactive power requirement. Harmonics may disrupt normal operation of other devices and increase operating costs. Symptoms of problematic harmonic levels include overheating of transformers, motors, drives, cables, thermal tripping of protective devices and logic faults of digital devices. In addition, the life span of many devices can be reduced by elevated operating temperature.

The Solution:

The AccuSine PCS+ AHF provides the simplest and most effective means to mitigate harmonics, to reduce process related voltage fluctuations. The AccuSine PCS+ AHF actively injects opposite harmonics current on the source side of the load and it:

- Decreases harmonic related overheating of cables, switchgear and transformers
- Reduces downtime caused by nuisance thermal tripping of protective devices
- Increases electrical network reliability and reduces operating costs
- Corrects to the 51st harmonic, reduce harmonics level to meet IEEE 519, IEC 61000 3-4, and UK G5/4-1 standards.
- Compensates entire network or specific loads depending on installation point

Standard Features:

- Real-time dynamic current injection for harmonic cancellation and VAR compensation (lead or lag power factor)
- Load balancing capability
- Parallel connection allows for easy retrofit and installation of multiple units for large networks
- Response to load fluctuations within 2 cycles for harmonics, 1/4 cycle for power factor or load balancing
- Full color touch screen HMI (Human Machine Interface)
- UL Type 1, UL Type 2, UL Type 12, IP31, and IP54 enclosures
- Seismic rated per ICC IBC and ASCE 7
- UL, CE, ABS, and CSA certified

AccuSine PCS+ Sizing

For proper sizing of AccuSine units, contact the Schneider Electric sales office or e-mail To expedite the product selection process, please have a single line diagram and/or details of the application including sizes of transformers, non-linear and linear loads, and any existing filters and capacitors.



4 POWER MONITORING AND CONTROL

Table 4.48: PCS+ Active Harmonic Filter Selection

Harmonic and PF Correction (380–480 V models, 50/60 Hz)							
Rated Current (A)	Frequency (Hz)	Catalog Number	Enclosure Information			Frame	Weight (kg)
			Rating	Style	Cable Entry		
60	50/60	PCSP060D5IP00	IP00 (UL Type Open)	Wall Mount	Bottom	1	88
		PCSP060D5N2	UL Type 2	Floor Standing	Top or Bottom	2	277
		PCSP060D5IP31	IP31				
		PCSP060D5N12	UL Type 12				
		PCSP060D5IP54	IP54				280
120	50/60	PCSP120D5IP00	IP00 (UL Type Open)	Wall Mount	Bottom	3	113
		PCSP120D5N2	UL Type 2	Floor Standing	Top or Bottom	4	287
		PCSP120D5IP31	IP31				
		PCSP120D5N12	UL Type 12				
		PCSP120D5IP54	IP54				293
200	50/60	PCSP200D5IP00	IP00 (UL Type Open)	Wall Mount	Bottom	5	171
		PCSP200D5N2	UL Type 2	Floor Standing	Top or Bottom	6	397
		PCSP200D5IP31	IP31				
		PCSP200D5N12	UL Type 12				
		PCSP200D5IP54	IP54				402
300	50/60	PCSP300D5IP00	IP00 (UL Type Open)	Wall Mount	Bottom	7	210
		PCSP300D5N2	UL Type 2	Floor Standing	Top or Bottom	8	422
		PCSP300D5IP31	IP31				
		PCSP300D5N12	UL Type 12				
		PCSP300D5IP54	IP54				436

NOTE: Contact Schneider Electric sales office for other voltage models.

New!

AccuSine PFV+ Active Harmonic Filter (AHF)

AccuSine PFV+ is a very simple and effective means to eliminate leading or lagging power factor, reduce voltage fluctuations, enhance equipment operating life, and improve system power capacity. AccuSine PFV+ offers many features in one package that others require multiple models to accomplish.

AccuSine PFV+ can help you solve:

- Power factor
- Imbalance (specifically important for motor applications)
- Voltage stability (such as localized photovoltaic networks)
- Flicker

AccuSine PFV+ Sizing

For proper sizing of AccuSine units, contact the Schneider Electric sales office or e-mail To expedite the product selection process, please have a single line diagram and/or details of the application including sizes of transformers, non-linear and linear loads, and any existing filters and capacitors.



Table 4.49: AccuSine PFV+ Selection

PF Correction and Load Balancing (380-480V models 50/60Hz)							
Rated Current (A)	Frequency (Hz)	Catalog Number	Rating	Enclosure Information		Frame	Weight (kg)
				Style	Cable Entry		
60	50/60	EVCP060D5IP00	IP00 (UL Type Open)	Wall Mount	Bottom	1	88
		EVCP060D5N2	UL Type 2	Floor Standing	Top or Bottom	2	277
		EVCP060D5IP31	IP31				280
		EVCP060D5N12	UL Type 12				
		EVCP060D5P54	IP54				
120	50/60	EVCP120D5IP00	IP00 (UL Type Open)	Wall Mount	Bottom	3	113
		EVCP120D5N2	UL Type 2	Floor Standing	Top or Bottom	4	287
		EVCP120D5 P31	IP31				293
		EVCP120D5N12	UL Type 12				
		EVCP120D5 P54	IP54				
200	50/60	EVCP200D5 P00	IP00 (UL Type Open)	Wall Mount	Bottom	5	171
		EVCP200D5N2	UL Type 2	Floor Standing	Top or Bottom	6	397
		EVCP200D5 P31	IP31				402
		EVCP200D5N12	UL Type 12				
		EVCP200D5 P54	IP54				
300	50/60	EVCP300D5 P00	IP00 (UL Type Open)	Wall Mount	Bottom	7	210
		EVCP300D5N2	UL Type 2	Floor Standing	Top or Bottom	8	422
		EVCP300D5 P31	IP31				436
		EVCP300D5N12	UL Type 12				
		EVCP300D5 P54	IP54				

4 POWER MONITORING AND CONTROL

AccuSine+ Wall Mount Conversion Kit

- Converts IP00 (UL Type Open) to IP20 (UL Type 1) wall mounted enclosed assemblies.
- Includes HMI mounting plate and cable entry enclosure for mounting on the bottom of the IP00 assemblies.

Table 4.50: AccuSine PCS+ and AccuSine PFV+ Exterior Dimensions

Frame Size	Exterior Dimensions	
	Height (mm)	Width (mm)
1	1300	421
2	2092	800
3	1400	421
4	2089	800
5	1323	582
6	2089	900
7	1560	582
8	2092	900

Table 4.51: AccuSine+ Wall Mount Kits

Catalog Number	Assembled Dimensions — IP20				IP20 Assembly	Cable Entry Enclosure
	Unit Rating (A)	Height	Width	Depth	Weight (kg)	Weight (kg)
PCSPWMKIT60A	60	1530	421	349	97.3	8.7
PCSPWMKIT120A	120	1730	421	384	122.0	9.3
PCSPWMKIT300A	200	1642	575	435	180.0	8.6
PCSPWMKIT300A	300	1882	575	435	218.6	8.6

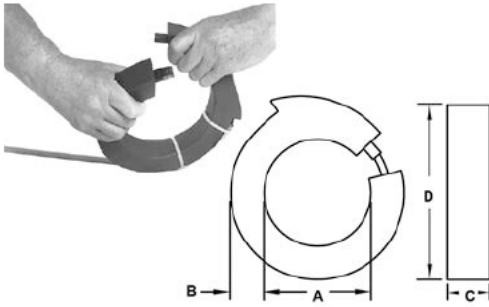

Round Split-Core Current Transformer (CT) Selection:

Two remote current transformers (CT) are required for three phase loads. Three CT's are required for networks with line to neutral loads. Depending on installation, additional CTs may be required. Additional sizes are available.

Table 4.52: Round Split-Core CT—UL Recognized

Ampacity	Catalog Number	Dimensions		Weight		Accuracy Class	Burden Capacity (VA)	Secondary Current	
		in	mm	lbs	kg				
1000	CT1000SC	A	4	101	3.5	1.75	1	10	5
		B	1.25	32					
		C	1.5	38					
		D	6.5	165					
3000	CT3000SC	A	6	152	4.25	1.90	1	45	5
		B	1.25	32					
		C	1.5	38					
		D	8.5	216					
5000	CTFC-L500058	A	8	203	5.5	2.50	1	45	5
		B	1.25	32					
		C	1.5	38					
		D	10.5	267					

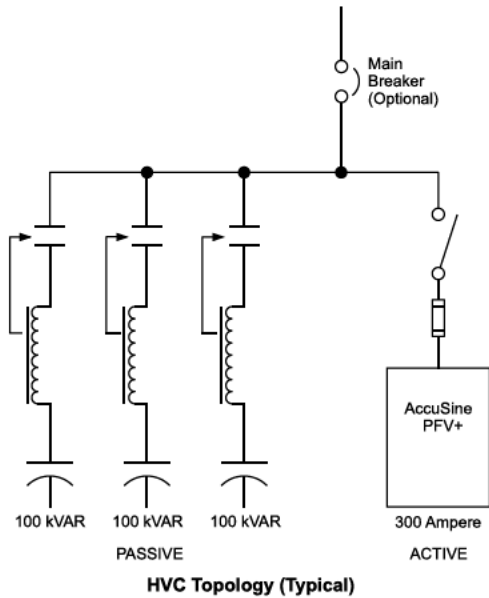

HVC Topology (Typical)

Main Features:

- Real-time reactive power compensation for transient or cyclical loads
- Infinite VAR resolution
- Transient free compensation
- Improves voltage stability, reduces flicker
- Constructed with 12 gauge steel frame

Hybrid VAR Compensator (HVC)

The Hybrid VAR Compensator (HVC) is ideally suited for industrial facilities with power quality or production problems caused by rapidly changing reactive power demands typically associating with highly cyclical loads such as welders, mining conveyors and heavy stamping machines.

The Problem: Rapid reactive power changes demand timely reactive power (VAR) compensation. Lack of timely and adequate VAR compensation can lead to voltage fluctuations in the electrical distribution system, impacting equipment operation, as well as product quality.

Traditional capacitor systems have a minimum response time of five to thirty seconds for load fluctuations. As a result of this limitation, uncompensated reactive power demand by cyclical loads can produce voltage instability, cause flicker, increase losses, and result poor power factor which reduces the electric supply capacity. Problems can include:

- Poor weld quality or reduced weld line productivity (due to restrikes or interlock weld controls)
- Failure to start motor loads (due to voltage sag on startup)
- Undervoltage tripping of sensitive loads (Robots, PLCs, VFDs)
- Lighting flicker and/or HID lighting shutdown
- Overloaded distribution equipment (cyclical current pulses may exceed the rated current of the distribution equipment)
- Poor power factor and associated utility demand charges

The Solution: The Hybrid VAR Compensator is ideally suited for ultra fast reactive power compensation in many low and medium voltage distribution networks containing highly transient loads where conventional systems are not suitable.

The HVC employs a fixed or automatic capacitor bank to provide reactive power at all times, while AccuSine PFV+ adjusts the output to meet system reactive power requirement in timely manner. AccuSine PFV+ provides dynamic VAR injection to meet reactive power requirement within 1/4 cycle, reduce voltage sags created by inductive load switching, welding operation, etc.

HVC systems can alleviate most of the problems created by cyclical loads that require large amount of reactive power for short duration. HVC system can be applied in the low voltage and medium voltage system from 480 V up to 33 kV.

Unique, cost-effective construction: The ReactiVar HVC is a custom engineered product designed for specific reactive power compensation requirements. It consists of both passive and active components. The passive component may consist of capacitors only or include tuned reactors. Depending on the application, the passive portion may include contactor or solid state switching device to permit some adjustment of the passive elements. The active component is provided by Schneider Electric's AccuSine PFV+ unit. HVC systems also can prevent resonance by including custom designed iron core reactors in series with each three phase capacitor module when required. The series reactor/capacitor combinations prevent resonance by turning the network below the first dominant harmonic (usually the 5th and 300 Hz). In doing so, HVC can also reduce harmonic voltage distortion, which further improves overall network conditions.

The HVC employs a fixed capacitor bank to inject leading reactive current (leading kVAR) into the network at all times, and an AccuSine PFV+ unit to precisely adjust the total output of the HVC according to the load reactive power demand profile. When load reactive demand is zero, the AccuSine PFV+ injects lagging reactive current to cancel the leading reactive current of the fixed capacitor bank such that the total output of the HVC is minimized. As the load kVAR demand increases, the AccuSine PFV+ adjusts its output such that the total output of the HVC precisely matches the load demand. If load demand increases above the fixed capacitor bank capability, then the AccuSine PFV+ injects leading reactive current. This continues until the full leading kVAR capacity of the AccuSine PFV+ is met. Thus, the HVC total output provides leading kVAR compensation to match load demand.

To optimize system design, Schneider Electric expert will normally need to take real-time measurements on the network site. Please contact Schneider Electric power quality experts or email us at



Plinth for Floor Mounting

VarSet Low Voltage Capacitor Banks

		Standard VLVAW2N	Standard VLVAW3N	Detuned VLVAF4P/ VLVFF4P
480 V 60 Hz	Lugs	25 to 100 KVAR	125 to 250 KVAR 125 to 300 KVAR	75 to 200 KVAR
	Incoming Circuit Breaker			
600 V 60 Hz	Lugs	25 to 100 KVAR	125 to 250 KVAR	75 to 200 KVAR
	Incoming Circuit Breaker			

Key Features

- Auxiliary transformer (120 V) included
- Top cable entry and connections
- NEMA 1

Options

- Incoming circuit breaker protection option with rotary handle
- Plinth accessory for floor mounting
 - Included for VLVAF4P and VLVFF4P version.
 - For VLVAW2N and VLVAW3N versions, order the following:
for Enclosure VLVAW2N: order NSYSPPF8100 and NSYSPPS4100
for Enclosure VLVAW3N: order NSYSPPF10100 and NSYSPPS4100
- Communication option: NRC12 controller + modbus communication module. Order your reference with addition of suffix C.
- Sprinkler proof: Included in 600 V offer

Table 4.53: General Characteristics

VarSet		
Environment		
Installation	Indoor	
Humidity	up to 95%	
Maximum altitude	2000 m	
Enclosure		
Degree of protection	NEMA 1	
Color	RAL 7035	
Degree of mechanical resistance	IK10	
Steps		
Step protection	With circuit breaker	
Electrical Characteristics		
Connection type	Three-phase	
Power losses	< 2.5 W/kVAR without detuned reactors < 6 W/kVAR with detuned reactors	
Tuning order (VarSet Detuned)	4.2 p.u. (60 Hz ref)	
Maximum permissible over voltage	1.1 x Un, 8 h every 24 h	
Standards		
CSA 22.2 No. 190		
UL810, UL508a		
Incoming Connection Short Circuit Rating	With Incoming Circuit Breaker	With Lugs
From 25 to 100 KVAR/no reactors	65 kA (480 V)	25 kA
	50 kA (600 V)	
From 125 to 300 KVAR/no reactors	65 kA (480 V)	25 kA
	50 kA (600 V)	
With reactors	65 kA (480 V)	25 kA
	50 kA (600 V)	

NOTE: A Current Transformer is required for automatic Control. In order to have automatic control, a current transformer must be ordered in addition to the PFC bank. A current transformer (not included) is necessary to provide accurate network information to the VarSet's controller in order to apply the correct quantity of KVAR at any given time. It is recommended to choose a Split Core Current Transformer Model 270R from the following list of options.

NOTE: CT must be sized to your network and have a secondary rating of 5A. More details on the CT can be found in document 4210CT9701.

NOTE: When selecting a CT, be sure to use proper rating factors for ambient temperature conditions.

Table 4.54: Current Transformers

Catalog Number	Current Rating (Amperes) ^[1]
270R-501	500:5
270R-102	1000:5
270R-152	1500:5
270R-202	2000:5
270R-302 [2]	3000:5
270R-402 [2]	4000:5

[1] Rating Factor 30 °C/80 °F Ambient Temp. = 1.33
Rating Factor 55 °C/131 °F Ambient Temp. = 1.0

[2] Models -302 and -402
Rating Factor 30 °C/80 °F Ambient Temp. = 1.0
Rating Factor 55 °C/131 °F Ambient Temp. = 0.75

VarSet Selection^[3]

Table 4.55: 480 V/60 Hz, Low-Polluted Network

Standard	Catalog Numbers	
Power	Lugs	Incoming CB
25	VLVAW2N66025AA	VLVAW2N66025AB
50	VLVAW2N66050AA	VLVAW2N66050AB
75	VLVAW2N66075AA	VLVAW2N66075AB
100	VLVAW2N66100AA	VLVAW2N66100AB
125	VLVAW3N66125AA	VLVAW3N66125AB
150	VLVAW3N66150AA	VLVAW3N66150AB
175	VLVAW3N66175AA	VLVAW3N66175AB
200	VLVAW3N66200AA	VLVAW3N66200AB
225	VLVAW3N66225AA	VLVAW3N66225AB
250	VLVAW3N66250AA	VLVAW3N66250AB
275	VLVAW3N66275AB	VLVAW3N66275AB
300	VLVAW3N66300AB	VLVAW3N66300AB

Table 4.56: 600 V/60 Hz, Low-Polluted Network

Standard	Catalog Numbers	
Power	Lugs	Incoming CB
25	VLVAW2N76025AA	VLVAW2N76025AB
50	VLVAW2N76050AA	VLVAW2N76050AB
75	VLVAW2N76075AA	VLVAW2N76075AB
100	VLVAW2N76100AA	VLVAW2N76100AB
125	VLVAW3N76125AA	VLVAW3N76125AB
150	VLVAW3N76150AA	VLVAW3N76150AB
175	VLVAW3N76175AA	VLVAW3N76175AB
200	VLVAW3N76200AA	VLVAW3N76200AB
225	VLVAW3N76225AA	VLVAW3N76225AB
250	VLVAW3N76250AA	VLVAW3N76250AB

Table 4.57: 480 V/60 Hz, Polluted Network, Detuned Reactors

Automatic	Catalog Numbers	
Power	Lugs	Incoming CB
75	VLVAF4P66075AA	VLVAF4P66075AB
100	VLVAF4P66100AA	VLVAF4P66100AB
125	VLVAF4P66125AA	VLVAF4P66125AB
150	VLVAF4P66150AA	VLVAF4P66150AB
175	VLVAF4P66175AA	VLVAF4P66175AB
200	VLVAF4P66200AA	VLVAF4P66200AB
Fixed	Catalog Numbers	
Power	Lugs	Incoming CB
75	VLVFF4P66075AA	VLVFF4P66075AB
100	VLVFF4P66100AA	VLVFF4P66100AB
125	VLVFF4P66125AA	VLVFF4P66125AB
150	VLVFF4P66150AA	VLVFF4P66150AB
175	VLVFF4P66175AA	VLVFF4P66175AB
200	VLVFF4P66200AA	VLVFF4P66200AB

Table 4.58: 600 V/60 Hz, Polluted Network, Detuned Reactors

Automatic	Catalog Numbers	
Power	Lugs	Incoming CB
75	VLVAF4P76075AA	VLVAF4P76075AB
100	VLVAF4P76100AA	VLVAF4P76100AB
125	VLVAF4P76125AA	VLVAF4P76125AB
150	VLVAF4P76150AA	VLVAF4P76150AB
175	VLVAF4P76175AA	VLVAF4P76175AB
200	VLVAF4P76200AA	VLVAF4P76200AB
Fixed	Catalog Numbers	
Power	Lugs	Incoming CB
75	VLVFF4P76075AA	VLVFF4P76075AB
100	VLVFF4P76100AA	VLVFF4P76100AB
125	VLVFF4P76125AA	VLVFF4P76125AB
150	VLVFF4P76150AA	VLVFF4P76150AB
175	VLVFF4P76175AA	VLVFF4P76175AB
200	VLVFF4P76200AA	VLVFF4P76200AB

Table 4.59: Physical and Electrical Steps (480 V and 600 V/60 Hz)

Type	kVAR	Min Step	Resolution	Num Mechanical Steps (CBs)	Num Electrical Steps	Sequence	Electrical Steps (Resolution)
Standard	25	125	2x12,5	2	2	1,111	12,5/25,0
	50	125	2x12,5 + 1x25	3	4	1,1 2 2	12,5/25,0/37,5/50,0
	75	125	1x12,5 + 1x25 + 1x37,5	3	6	1,233	12,5/25,0/37,5/50,0/62,5/ 75,0
	100	25	2x25 + 50	3	4	1,122	25/50/75/100
	125	25	1x25 + 2x50	3	5	1 2 2 2	25/50/75/100/125
	150	25	2x25 + 2x50	4	6	1,1 2 2	25/50/75/100/125/150
	175	25	1x25 + 3x50	4	7	1,222	25/50/75/100/125/150/175
	200	25	2x25 + 3x50	5	5	11,222	25/50/75/100/125/150/ 175/200
	225	25	1x25 + 4x50	5	9	1 2 2 2	25/50/75/100/125/150/175/ 200/225
	250	50	5x50	5	5	1,111	50/100/150/200/250
	275	25	1x25 + 5x50	6	11	1,222	25/50/75/100/125/150/175/ 200/225/250/275
	300	50	6x50	6	6	1,1,1,1	50/100/150/200/250/300
Detuned	75	25	1x25 + 1x50	2	3	1,222	25/50/75
	100	25	2x25 + 1x50	3	4	1,122	25/50/75/100
	125	25	1x25 + 2x50	3	5	1 2 2 2	25/50/75/100/125
	150	25	2x25 + 2x50	4	6	1,122	25/50/75/100/125/150
	175	25	1x25 + 3x50	4	7	1 2 2 2	25/50/75/100/125/150/175
200	50	4x50	4	4	1,111	50/100/150/200	

VarSet Dimensions and Weights

Table 4.60: VLVAW2N

	VLVAW2N [4]
H	850 mm / 33.5 in.
W	800 mm / 31.5 in.
D	400 mm / 15.7 in.
D1	1200 mm / 47.2 in.
Weight	80 kg / 175 lbs.

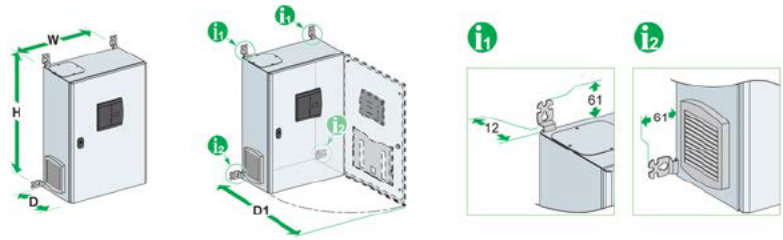

VLVAW2N

Table 4.61: VLVAW3N

	VLVAW3N [4]
H	1200 mm / 47.2 in.
W	1000 mm / 39.4 in.
D	400 mm / 15.7 in.
D1	1400 mm / 55.1 in.
Weight	125 kg / 275 lbs.

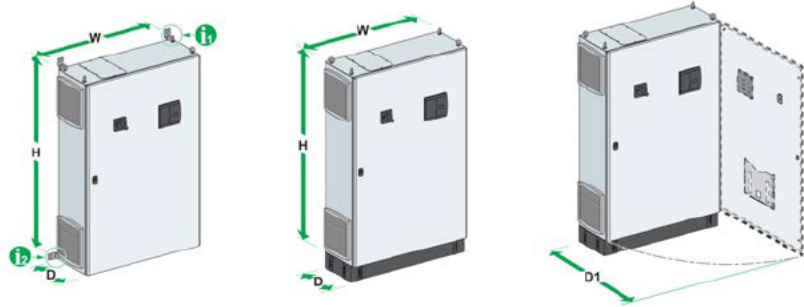

VLVAW3N

Table 4.62: VLVAF4P and VLVFF4P

	VLVAF4P / VLVFF4P
H	1200 mm / 47.2 in.
W	1300 mm / 51.2 in.
D	400 mm / 15.7 in.
D1	1200 mm / 47.2 in.
Weight	265 kg / 585 lbs.

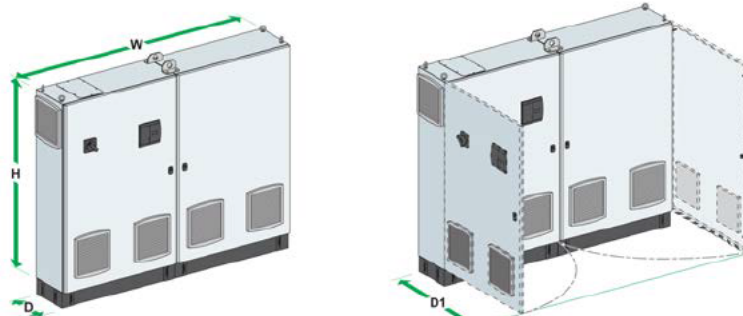

VLVAF4P and VLVFF4P

[4] Does not include plinth for VLVAW2N and VLVAW3N, optional, which adds 100 mm to height.